

LBH-781/LBH-782/LBH-783/LBH-784/LBH-781-K/LBH-782-K/LBH-783-K/LBH-784-K

FRAME & MISCELLANEOUS COVER COMPONENTS (1)

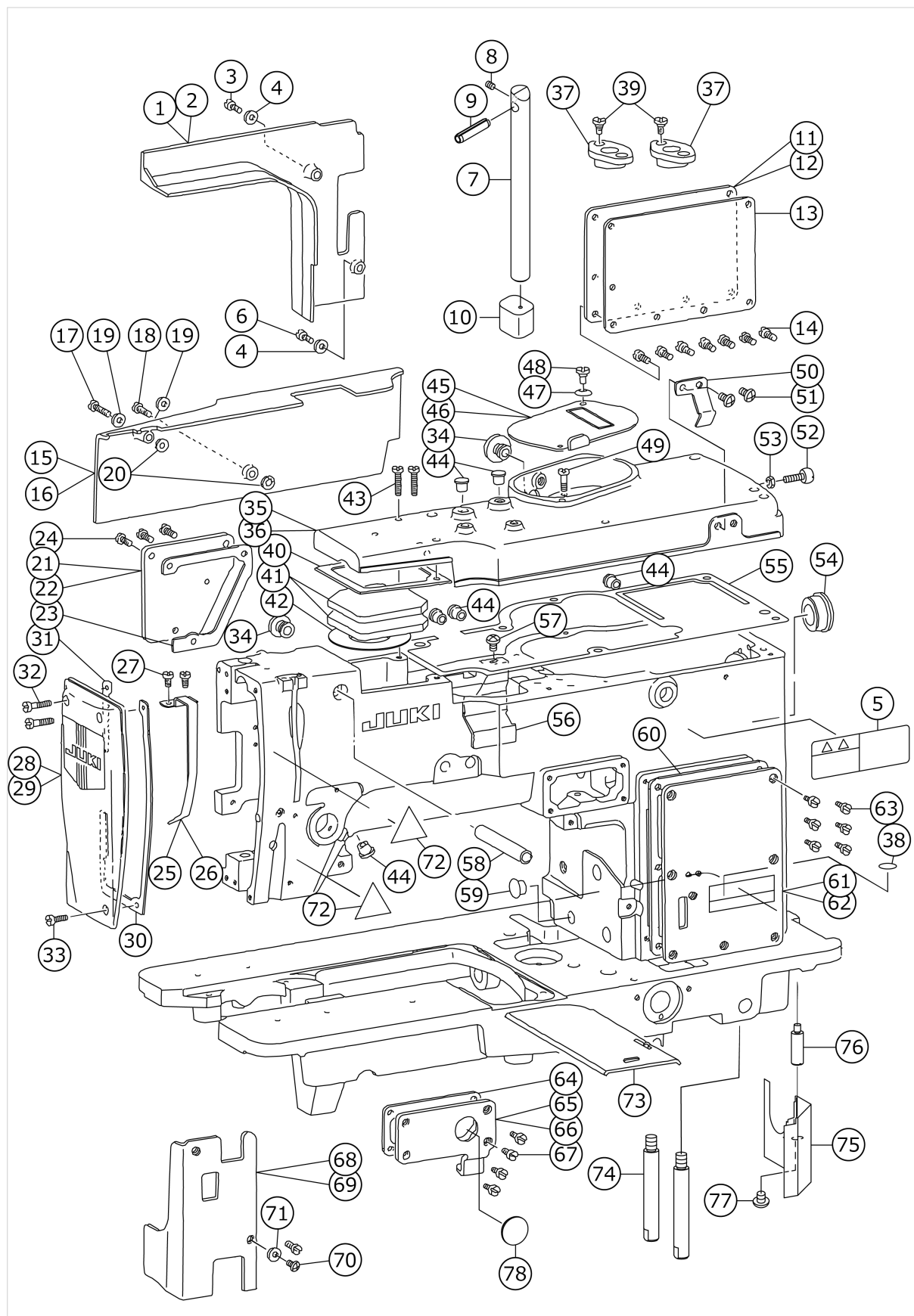

No.	品番	品名	備考	子部品	消耗品	個数
1	B1137771000	FRAME SIDE COVER B				1.00
2	B113777100A	FRAME SIDE COVER B	FOR URBAN WHITE			1.00
3	SS4111015SP	SCREW 11/64-40 L=10				1.00
4	WP0450000SD	WASHER 4.5X8X0.5				2.00
5	CM301300001	SAFETY LABEL				1.00
6	SS4111015SP	SCREW 11/64-40 L=10				1.00
7	40009028	ARM SUPPORT ROD				1.00
8	SS8110510SP	SCREW 11/64-40 L=5				1.00
9	B1120761000	PIN				1.00
10	B1118761000	RUBBER CUSHION				1.00
11	B1116771000	SIDE COVER (C)				1.00
12	40009010	ARM SIDE COVER (C)	FOR URBAN WHITE			1.00
13	B1152771000	SIDE COVER GASKET (C)				1.00
14	SS4110915SP	SCREW 11/64-40 L=9				7.00
15	B1138771000	FRAME SIDE COVER C				1.00
16	B113877100A	FRAME SIDE COVER C	FOR URBAN WHITE			1.00
17	SS4112215SP	SCREW 11/64-40 L=22				1.00
18	SS4111415SP	SCREW 11/64-40 L=14				1.00
19	B1155771000	CUSHION				2.00
20	B1144771000	FRAME SIDE COVER GASKET (C)				2.00
21	B1153781000	LEFT SIDE COVER				1.00
22	40008995	LEFT SIDE COVER	FOR URBAN WHITE			1.00
23	B1145771000	SIDE COVER GASKET				1.00
24	SS4110915SP	SCREW 11/64-40 L=9				3.00
25	B1123581000	THREAD TAKE-UP LEVER OIL GUARD				1.00
26	40009039	THREAD TAKE-UP LEVER COVER	FOR URBAN WHITE			1.00
27	SS4090515SP	SCREW 9/64-40 L=5				2.00
28	B11127710A0	FACE COVER COMPLETE				1.00
29	B11127710AA	FACE COVER COMPLETE	FOR URBAN WHITE			1.00
30	B1149771000	GASKET				1.00
31	B1151771000	FACE PLATE GASKET (B)				1.00
32	SS4111415SP	SCREW 11/64-40 L=14				2.00
33	SS4110915SP	SCREW 11/64-40 L=9				1.00
34	TA1250705R0	RUBBER PLUG				2.00
35	B1103771000A	TOP COVER				1.00
36	B110377100A	TOP COVER	FOR URBAN WHITE			1.00
37	B1106771000	WORM GEAR SHAFT METAL				2.00
38	10004109	GROUND MARK				1.00
39	SS6120620TP	SCREW				4.00
40	B1110771000	TOP COVER GASKET, FRONT				1.00
41	B1117771000	OIL FELT				2.00
42	40009050	MAIN SHAFT THRUST SEEL				1.00
43	SS4111815SP	SCREW 11/64 L=18				6.00

44	TA0750704R0	RUBBER PLUG				6.00
45	B1106761000	GEAR CASE COVER				1.00
46	40009030	GEAR CASE COVER	FOR URBAN WHITE			1.00
47	B3125155000	DISK SPRING				1.00
48	SD0640261SP	HINGE SCREW D=6.35 H=2.6				1.00
49	SS7111310SP	SCREW 11/64-40 L=12.8				1.00
50	40009311	HAND STOP LATCH				1.00
51	SS4110715SP	SCREW 11/64-40 L=7				2.00
52	40009038	BALL SCREW				1.00
53	NS6120310SP	NUT 3/16-28				1.00
54	TA2101002R0	RUBBER PLUG				1.00
55	B1104771000	TOP COVER GASKET, REAR				1.00
56	40009370	ARM OIL SHIELD				1.00
57	SS4110715SP	SCREW 11/64-40 L=7				1.00
58	B2743771000	KNIFE STOP LEVER SHAFT GUIDE				1.00
59	TA1050504R0	RUBBER PLUG				1.00
60	B1111771000	SIDE COVER (A) GASKET				1.00
61	B1114771000	SIDE COVER (A)				1.00
62	40009008	ARM SIDE COVER (A)	FOR URBAN WHITE			1.00
63	SS4110915SP	SCREW 11/64-40 L=9				6.00
64	B1133771000	OIL SIGHT WINDOW GASKET				1.00
65	B11157710A0	SIDE COVER ASM. B				1.00
66	40009009	ARM SIDE COVER (B)	FOR URBAN WHITE			1.00
67	SS4110915SP	SCREW 11/64-40 L=9				4.00
68	B1128771000	SIDE COVER A				1.00
69	B112877100A	SIDE COVER A	FOR URBAN WHITE			1.00
70	SS4111015SP	SCREW 11/64-40 L=10				2.00
71	WP0450000SD	WASHER 4.5X8X0.5				2.00
72	CM300200001	ATTENTION SEAL				2.00
73	40009034	BED SLIDE				1.00
74	40009036	BED SCREW STUD A				2.00
75	40009363	BED OIL SHIELD ASM.				1.00
76	40009384	BED OIL SHIELD STUD				1.00
77	SS4110515SP	SCREW 11/64-40 L=5				1.00
78	40009014	OIL SIGHT WINDOW				1.00

# FRAME & MISCELLANEOUS COVER COMPONENTS (2)

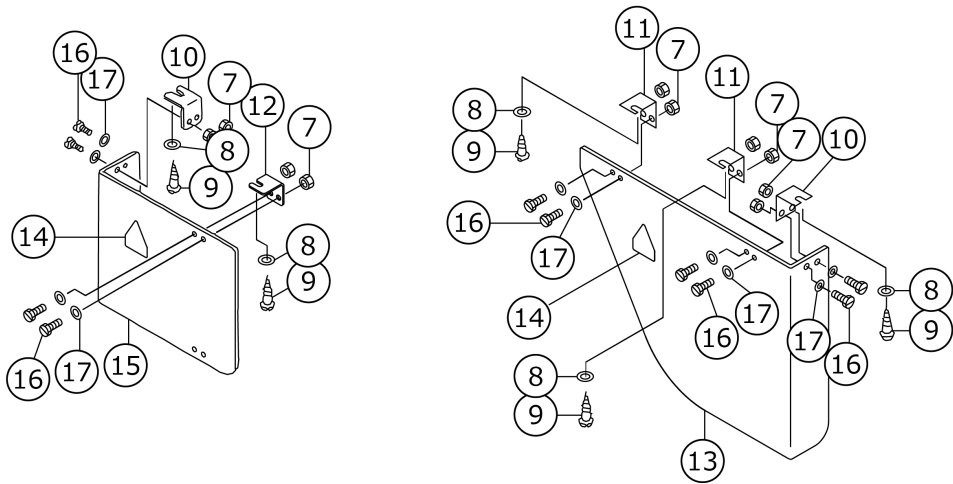
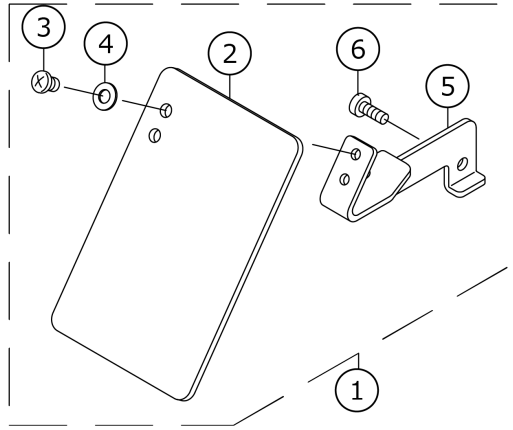



No.	品番	品名	備考	子部品	消耗品	個数
1	40052419	SAFETY PLATE ASM.	FOR USE IN JAPAN			1.00
2	26037200	SAFETY PLATE		*		1.00
3	SM4040655SP	SCREW M4 L=6		*		2.00
4	WP0450801SD	WASHER 4.5X10X0.8		*		2.00
5	40052354	SAFETY PLATE INSTALLING BASE		*		1.00
6	SS6111140SP	SCREW 11/64-40 L=11		*		1.00
7	NS6110310SP	NUT 11/64-40	FOR USE IN JAPAN			10.00
8	WP0501016SC	WASHER 5X10.5X1	FOR USE IN JAPAN			5.00
9	SK3452000SE	WOOD SCREW D=4.5 L=20	FOR USE IN JAPAN			5.00
10	B7272781000	COVER MOUNTING BRACKET B	FOR USE IN JAPAN			2.00
11	40009421	COVER MOUNTING BRACKET A	FOR USE IN JAPAN			2.00
12	26236703	COVER MOUNTING BRACKET C	FOR USE IN JAPAN			1.00
13	13772504	MOTOR PULLEY COVER	FOR USE IN JAPAN			1.00
14	CM3002000A3	LABEL,(31.5)	FOR USE IN JAPAN			2.00
15	40009458	PULLEY COVER	FOR USE IN JAPAN			1.00
16	SS7110710SP	SCREW 11/64-40 L=7	FOR USE IN JAPAN			10.00
17	WP0480856SP	WASHER 4.8X8.4X0.8	FOR USE IN JAPAN			10.00

# MAIN SHAFT COMPONENTS

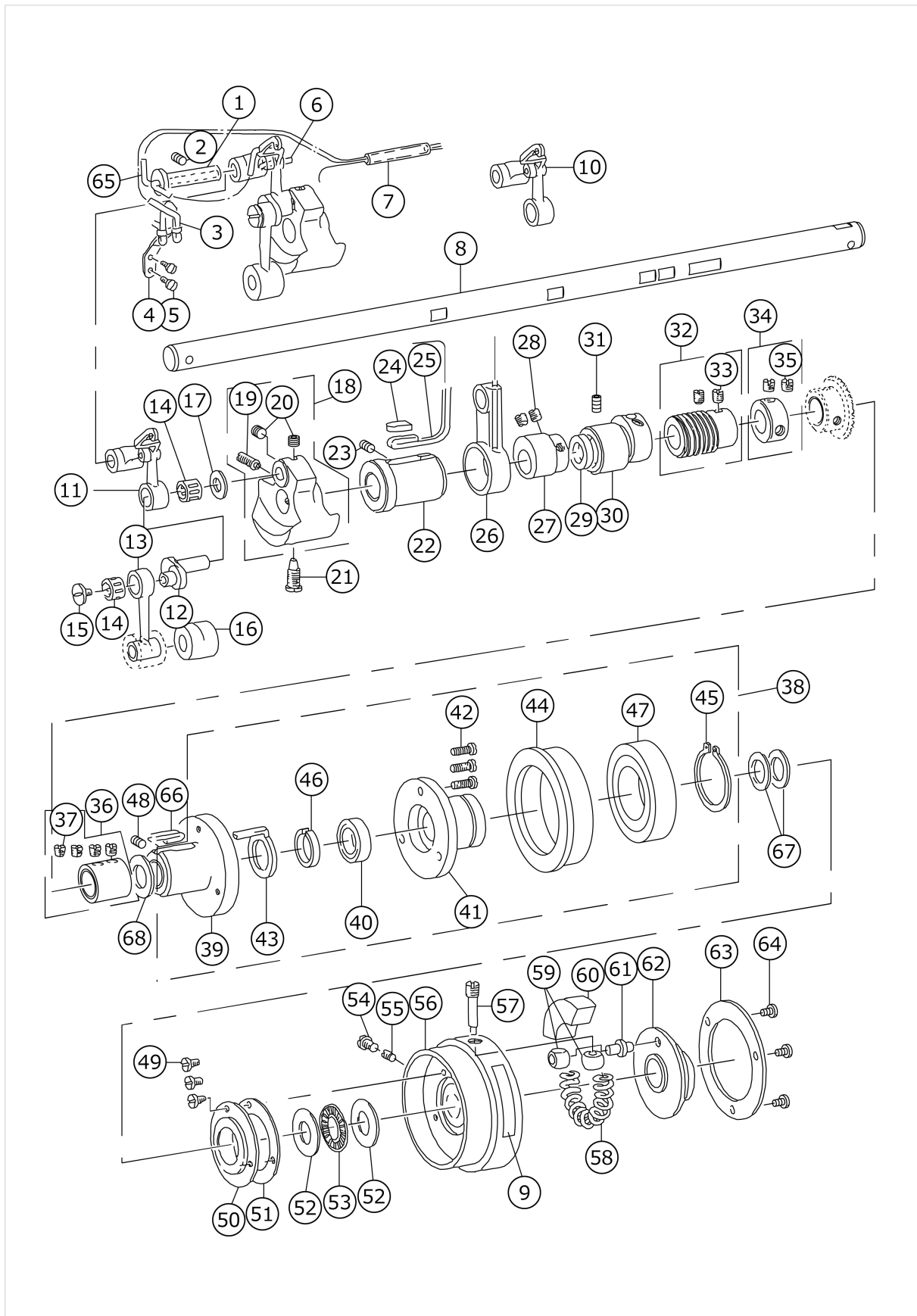

No.	品番	品名	備考	子部品	消耗品	個数
1	B1404761000	HINGE STUD				1.00
2	SS8150822TP	SCREW 15/64-28 L=8				1.00
3	CQ252000000	OIL WICK				0.38
4	40009087	OIL WICK HOLDER				1.00
5	SS7090510SP	SCREW 9/64-40 L= 4.6				2.00
6	B1147125000	OIL WICK SNAP RING				1.00
7	BP600000000	VINYL PIPE				0.03
8	40008610	MAIN SHAFT				1.00
9	CM500300001	DIRECTION LABEL				1.00
10	B1901761BA0	THREAD TAKE-UP LEVER ASM.	SPECIAL ORDER PARTS			1.00
11	B19017610A0	THREAD TAKE-UP LEVER ASM.				1.00
12	B1203771000	NEEDLE BAR CRANK				1.00
13	B1204761000	NEEDLE BAR CRANK CONNECTING ROD				1.00
14	B1905541B00	NEEDLE BEARING	SELECTIVE PARTS			2.00
15	B1903552000	LEFT SCREW				1.00
16	B2615232000	OIL FELT WASHER				1.00
17	B1223771000	NEEDLE ROD CRANK WASHER				1.00
18	40009048	COUNTERWEIGHT ASM.				1.00
19	SS8681650TP	SCREW 9/32-28 L=16		*		1.00
20	SS8660512TP	SCREW 1/4-40 L=5		*		2.00
21	SS7681750TP	SCREW 9/32-28 L=16.5				1.00
22	B1204771000A	BUSHING, FRONT				1.00
23	SS8150822TP	SCREW 15/64-28 L=8				2.00
24	B1203012000	OIL FELT				1.00
25	B3541012000	OIL WICK				1.00
26	26100701	KNIFE BAR DRIVING CONNECTING				1.00
27	B2722761000	KNIFE BAR DRIVING ECCENTRIC				1.00
28	SS8660810TP	SCREW 1/4-40 L=8				2.00
29	B1208552000A	OIL SEAL				1.00
30	26104703	MAIN SHAFT BUSHING INTERMEDIATE				1.00
31	SS8150822TP	SCREW 15/64-28 L=8				1.00
32	B29207610A0	WORM ASM.				1.00
33	SS8660610TP	SCREW 1/4-40 L=6		*		2.00
34	CS147121BSH	THRUST COLLAR ASM. D=14.72 W=12				1.00
35	SS8660530TP	SCREW 1/4-40 L= 4.5		*		2.00
36	40009400	MAIN SHAFT THRUST COLLAR ASM.				1.00
37	SS8660530TP	SCREW 1/4-40 L= 4.5		*		4.00
38	B12567810A0A	UPPER SHAFT REAR METAL ASM.				1.00
39	B1256781000A	UPPER SHAFT REAR METAL		*		1.00
40	B1208552000A	OIL SEAL		*		1.00
41	40009426	BEARING RETAINER		*		1.00
42	SS7110910TP	SCREW 11/64-40 L= 8.5		*		3.00
43	B1257781000	FELT B		*		1.00
44	40009427	LOOSE PULLEY		*		1.00
45	RC3000001KP	RETAINING RING 30		*		1.00
46	40009462	FELT-B GUIDE		*		1.00
47	SB130000100	BEARING D=30X55		*		1.00
48	SS8150822TP	SCREW 15/64-28 L=8				1.00

49	SS7090410SP	SCREW 9/64-40 L= 3.5				3.00
50	B1254781000	MAIN SHAFT THRUST SEEL				1.00
51	B1227771000	GASKET				1.00
52	B1220771000	THRUST WASHER A				2.00
53	B1225771000	BEARING				1.00
54	SS7660510SP	SCREW 1/4-40 L=5.0				1.00
55	SS8660512TP	SCREW 1/4-40 L=5				1.00
56	40009049	DRIVING PULLEY				1.00
57	B122477100C	SCREW (C)	SELECTIVE PARTS			1.00
58	B1231771000	STOP CAM PRESSURE SPRING				1.00
59	40009070	STOP-MOTION CAM PIN SLIDE BLOCK				2.00
60	B1212232000	BAKELITE SEGMENT				1.00
61	40009069	STOP-MOTION CAM POSITION PIN				1.00
62	B1208771000	STOP MOTION CAM				1.00
63	40009058	STOP MOTION CAM PRESSER PLATE				1.00
64	SS7110710SP	SCREW 11/64-40 L=7				3.00
65	CQ252000000	OIL WICK				0.40
66	B3541012000	OIL WICK				1.00
67	B125578100B	WASHER B	SELECTIVE PARTS			2.00
68	B1229771000	MAIN SHAFT THRUST WASHER (C)				1.00

# HOOK DRIVING SHAFT COMPONENTS

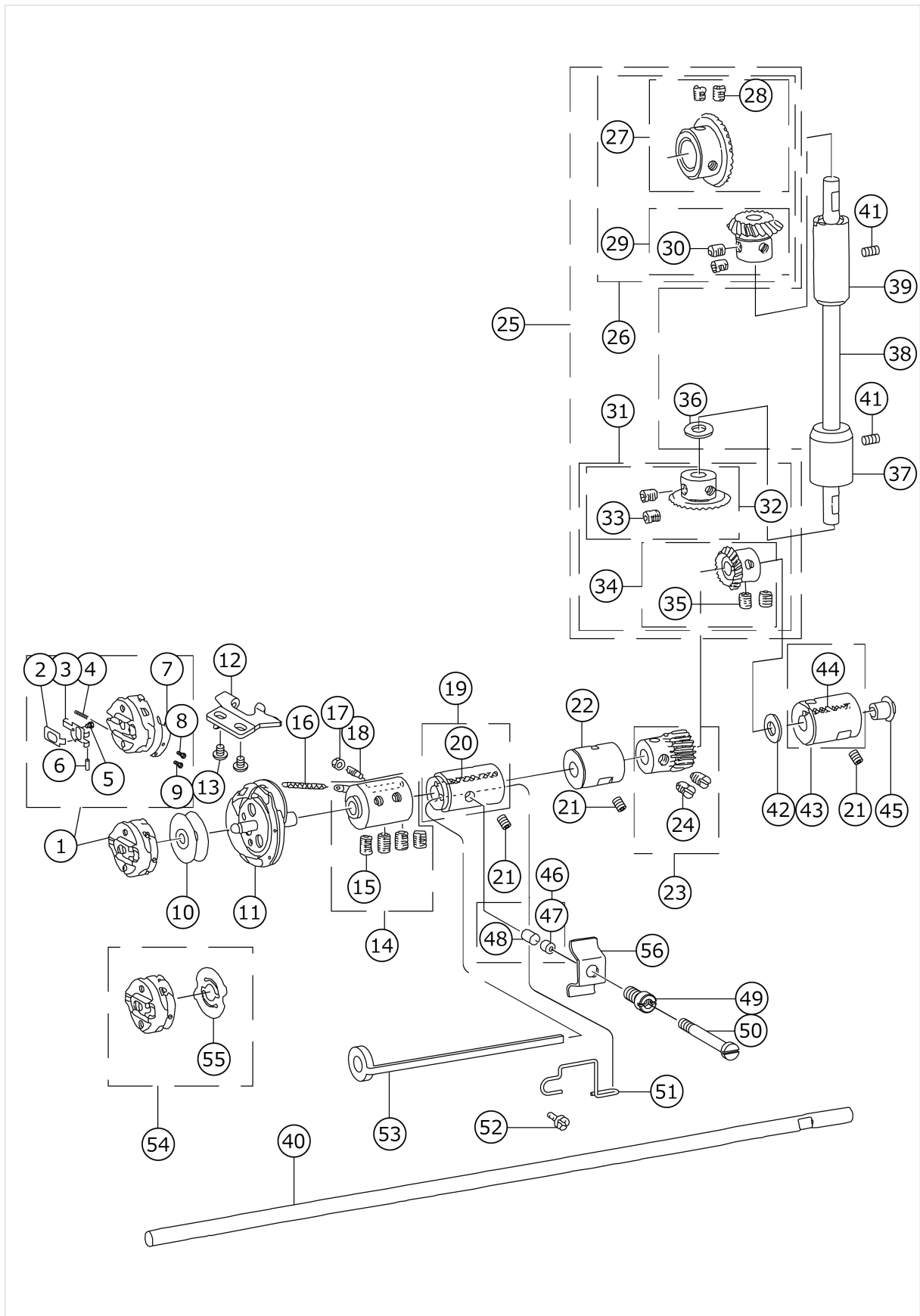

No.	品番	品名	備考	子部品	消耗品	個数
1	B18107710A0	BOBBIN CASE ASM.				1.00
2	B1810761C00	BOBBIN CASE LATCH LEVER		*		1.00
3	B1810761B00	BOBBIN CASE LATCH		*		1.00
4	B1810761F00	LATCH SPRING		*		1.00
5	B1810761G00	LATCH STOP SCREW		*		1.00
6	B1810761D00	HINGE PIN		*		1.00
7	B1810771E00	TENSION SPRING		*		1.00
8	B1810761J00	TENSION SCREW		*		1.00
9	B1810761H00	CLAMP SCREW		*		1.00
10	40009148	BOBBIN				1.00
11	B18087710AC	HOOK ASM.				1.00
12	26100404	BOBBIN CASE POSITIONING PLATE				1.00
13	SS4110515SP	SCREW 11/64-40 L=5				1.00
14	B18057710A0	HOOK SLEEVE ASM.				1.00
15	SS8660612TP	SCREW 1/4-40 L=6		*		4.00
16	B18127710A0	OIL WICK ASM.				1.00
17	NS6090310SP	NUT 9/64-40				1.00
18	B1806771000	ADJUSTING SCREW				1.00
19	B18047610A0	BUSHING ASM., FRONT				1.00
20	CQ252000000	OIL WICK		*		0.03
21	SS8150822TP	SCREW 15/64-28 L=8				3.00
22	B1803761000	BUSHING, INTERMEDIATE				1.00
23	B1446761CA0	PINION ASM.	SELECTIVE PARTS			1.00
24	SS8660610TP	SCREW 1/4-40 L=6		*		2.00
25	B13067710C0	GEAR & PINION ASM.				1.00
26	B13067710B0	GEAR & PINION ASM. UPPER		*		1.00
27	B13057710A0	GEAR ASM.		*		1.00
28	SS6660712TP	SCREW 1/4-40 L= 7.0		*		2.00
29	B13067710A0	PINION ASM.		*		1.00
30	SS6660712TP	SCREW 1/4-40 L= 7.0		*		2.00
31	B13077710B0	GEAR & PINION ASM. LOWER		*		1.00
32	B13077710A0	GEAR ASM.		*		1.00
33	SS6660712TP	SCREW 1/4-40 L= 7.0		*		2.00
34	B13087710A0	PINION ASM.		*		1.00
35	SS6660712TP	SCREW 1/4-40 L= 7.0		*		2.00
36	B1223771000	NEEDLE ROD CRANK WASHER				1.00
37	22905202	UPRIGHT SHAFT BUSHING, LOWER				1.00
38	40009071	UPRIGHT SHAFT				1.00
39	40009072	UPRIGHT SHAFT BUSHING				1.00
40	40009150	HOOK DRIVING SHAFT				1.00
41	40061518	SCREW				2.00
42	B1223771000	NEEDLE ROD CRANK WASHER				1.00
43	B18027710A0	BUSHING ASM., REAR				1.00
44	CQ202000000	OIL WICK		*		0.10
45	TA0850604R0	RUBBER PLUG				1.00
46	40009442	HOOK OIL SUPPLY RUBBER ASM.				1.00
47	40009443	BUSHING		*		1.00
48	40009444	OIL ADJUSTING RUBBER		*		1.00
49	40009156	HOOK OIL ADJUSTING SCREW				1.00

50	40009157	POSITIONING SCREW				1.00
51	40009153	OIL SUPPLY FELT HOLDER				1.00
52	SS4150715SP	SCREW 15/64-28 L=7				1.00
53	B1812761000	OIL SUPPLY FELT				1.00
54	B18107710BA	BOBBIN CASE ASM.	SPECIAL ORDER PARTS FOR SYNT HETIC THREAD			1.00
55	B1814761000	SPRING	SPECIAL ORDER PARTS FOR SYNT HETIC THREAD	*		1.00
56	40009155	PLATE SPRING				1.00

# PRESSER BAR & WORK CLAMP CARRIER COMPONENTS

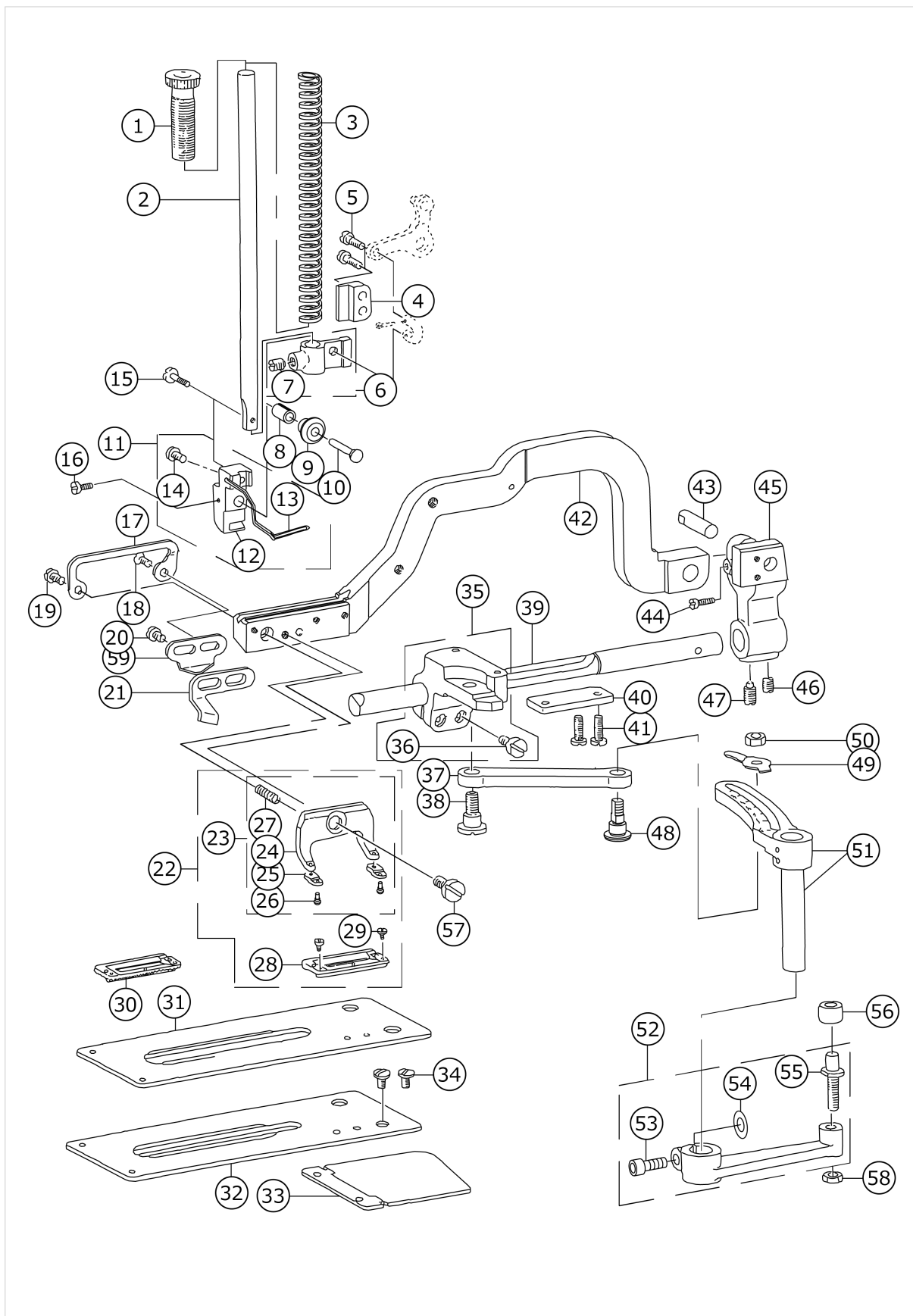



No.	品番	品名	備考	子部品	消耗品	個数
1	40009129	PRESSER SPRING REGULATOR				1.00
2	40009119	PRESSER BAR				1.00
3	B1507761000	PRESSER SPRING				1.00
4	B1506761000	PRESSER BAR GUIDE BRACKET				1.00
5	SS7111310SP	SCREW 11/64-40 L=12.8				2.00
6	B15057610A0	PRESSER BAR POSITION BRACKET ASM.				1.00
7	SS8660810TP	SCREW 1/4-40 L=8		*		1.00
8	40009121	SLEEVE				1.00
9	40009123	SLIDE ROLLER				1.00
10	B1503771000	CONNECTING PIN				1.00
11	B1502771AA0A	BRACKET ASM.				1.00
12	40009131	BRACKET		*		1.00
13	40009132	FINGER GUARD		*		1.00
14	SS7090710SP	SCREW 9/64-40 L= 6.8		*		1.00
15	SS4091520SP	SCREW 9/64-40 L=15				1.00
16	SS7110710SP	SCREW 11/64-40 L=7				1.00
17	40009122	WORK CLAMP BRACKET				1.00
18	SS2110920TP	SCREW 11/64-40 L=8.5				1.00
19	SS7110840SP	SCREW 11/64-40 L=7.8				1.00
20	SS7110840SP	SCREW 11/64-40 L=7.8				1.00
21	40009190	NEEDLE THREAD TRIMMER GUIDE (A)				1.00
22	B15527810A0A	PRESSER ASM.				1.00
23	B15117710A0B	PRESSER FOOT ASM.	THE SIZE OF THE BUTTONHOLE VARIES ACCORDING TO THE WORK CLAMP CHECK, SO FOR FURTHER DETAILS PLEASE REFER TO PAGE 39,22-(2).	*		1.00
24	B1511771000B	PRESSER FOOT		*		1.00
25	B1509761000	WORK CLAMP CHECK SPRING		*		2.00
26	B151077100B	WORK CLAMP CHECK SPRING SET PIN (B)		*		2.00
27	B1512761000	WORK CLAMP CHECK HOLDER SPRING		*		1.00
28	B1552781000A	WORK CLAMP CHECK		*		1.00
29	SS6060210SP	SCREW 3/32-56 L= 1.9		*		2.00
30	B1508771A00	WORK CLAMP CHECK	SPECIAL ORDER PARTS FOR LIGHT WEIGHT KNIT MATERIALS.(PLEASE USE THE WORK CLAMP CHECK AND THE WORK CLAMP CARRIER TOGETHER AS A PAIR.)			1.00
31	B1613771A00A	WORK CLAMP CARRIER	SPECIAL ORDER PARTS FOR LIGHT WEIGHT KNIT MATERIALS.(PLEASE USE THE WORK CLAMP CHECK AND THE WORK CLAMP CARRIER TOGETHER AS A			1.00

32	40009445	WORK CLAMP CARRIER				1.00
33	B16077630A0	BRACKET COVER				1.00
34	SS5110810SP	SCREW 11/64-40 L=8				2.00
35	B16117710A0	WORK CLAMP ARM BRACKET ASM.				1.00
36	SS6151440SP	SCREW 15/64-28 L=14		*		2.00
37	B1606763000	WORK CLAMP CARRIER BRACKET PITMAN				1.00
38	SD0870601SP	HINGE SCREW D= 8.73 H= 6.0				1.00
39	26105908	WORK CLAMP ARM SLIDE ROD				1.00
40	B1612763000	WORK CLAMP CARRIER BRACKET GUIDE				1.00
41	SS6111010TP	SCREW 11/64-40 L= 9.5				2.00
42	B1551781000	WORK CLAMP				1.00
43	B1517761000	CONNECTING PIN				1.00
44	SS7090920SP	SCREW 9/64-40 L= 8.5				1.00
45	B1516771000	BEARING ARM				1.00
46	SS8150710SP	SCREW 15/64-28 L=7				1.00
47	SS8150920SP	SET-SCREW				1.00
48	40009137	LENGTH REGULATING HINGE STUD				1.00
49	40009134	LENGTH REGULATING SHAFT GUIDE				1.00
50	NS6150310SP	NUT 15/64-28				1.00
51	B16037630A0	LENGTH REGULATING SCALE ASM.				1.00
52	40009144	LENGTH REGULATING SHAFT CRANK				1.00
53	SM6061602TP	SCREW M6 L=16		*		1.00
54	WP0650876SD	WASHER 6.5X13X0.8		*		1.00
55	40009146	BELL CRANK ROLLER STUD		*		1.00
56	40009143	ROLLER				1.00
57	SD0790203SP	HINGE SCREW D=7.94 H=2				1.00
58	NS6150310SP	NUT 15/64-28				1.00
59	40009178	NEEDLE THREAD TRIMMER GUIDE (B)				1.00

# NEEDLE BAR FRAME COMPONENTS

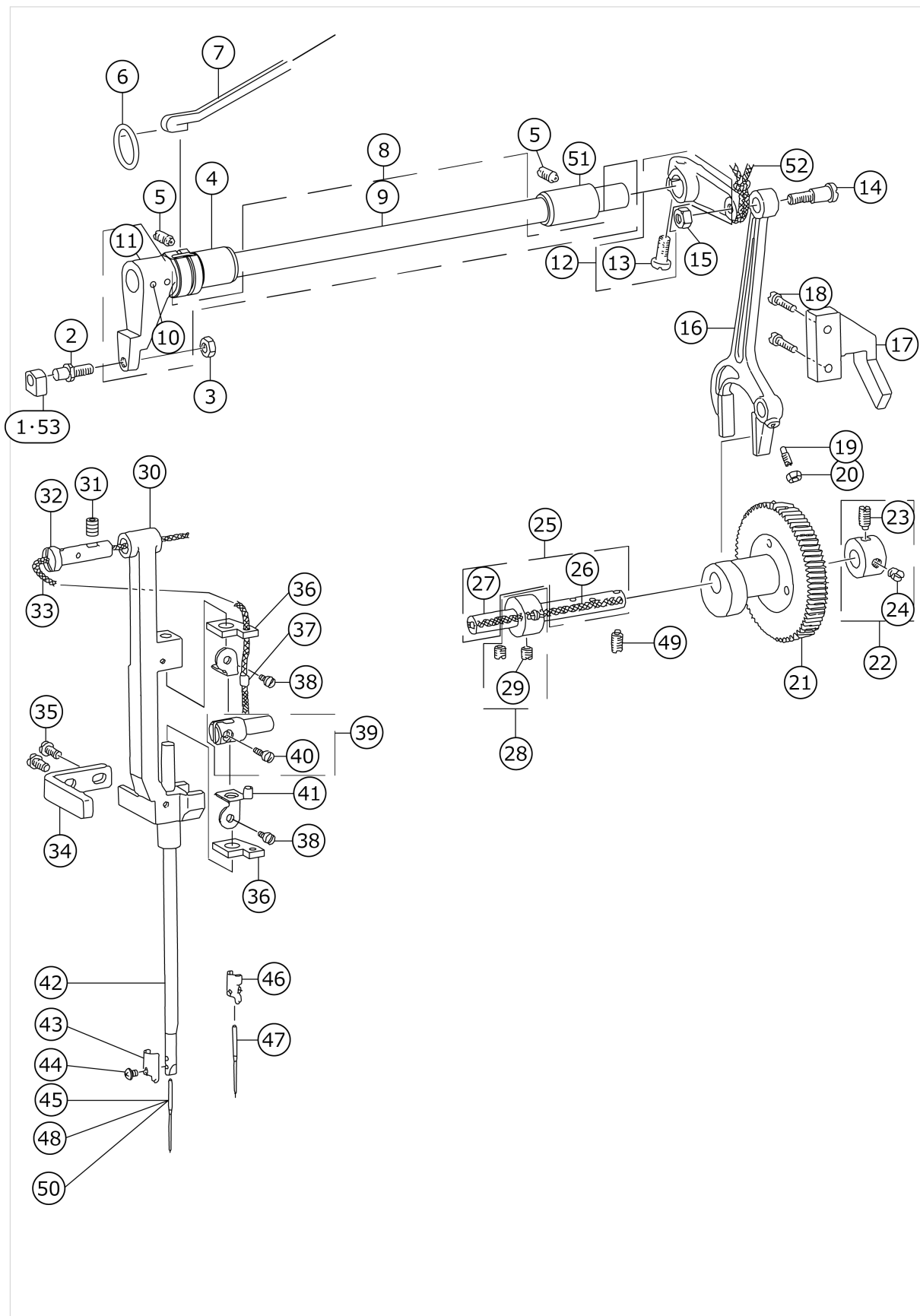

No.	品番	品名	備考	子部品	消耗品	個数
1	B1414232000	SQUARE BLOCK	SELECTIVE PARTS			1.00
2	B1410771000	STUD				1.00
3	NS6150310SP	NUT 15/64-28				1.00
4	40009082	BUSHING				1.00
5	SS8151150SP	SCREW 15/64-28 L=10.5				2.00
6	RO148240200	RUBBER RING				1.00
7	B3541012000	OIL WICK				1.00
8	B14117710A0	FRAME ROCK SHAFT CRANK ASM.				1.00
9	26106906	FRAME NEEDLE BAR SHAFT		*		1.00
10	PT0302000S0	TAPERED PIN 3.0X20		*		2.00
11	40009099	NEEDLE BAR CRANK (FRONT)		*		1.00
12	40009452	NEEDLE BAR CRANK (REAR) ASM.				1.00
13	SS7151210SP	SCREW 15/64-28 L=12		*		1.00
14	SD0790801SP	HINGE SCREW D=7.94 H=8				1.00
15	NS6160520SP	NUT 1/4-24				1.00
16	B1415761000	NEEDLE BAR PITMAN				1.00
17	B1416761000	ROCK SHAFT CONNECTION GUIDE				1.00
18	SS6111210SP	SCREW 11/64-40 L=12				2.00
19	SS8111251SP	SCREW 11/64-40 L=12.0				1.00
20	NS6110310SP	NUT 11/64-40				1.00
21	B14457610A0	NEEDLE DRIVING GEAR ASM.				1.00
22	CS095101CSH	THRUST COLLAR ASM. D=9.53 W=10				1.00
23	SS8150920SP	SET-SCREW		*		1.00
24	SS8150710SP	SCREW 15/64-28 L=7		*		1.00
25	B14477610A0	KNIFE DRIVING SHAFT ASM.				1.00
26	CQ202000000	OIL WICK		*		0.21
27	40009091	KNIFE DRIVING SHAFT		*		1.00
28	CS095101BSH	THRUST COLLAR ASM. D=9.53 W=10				1.00
29	SS8150710SP	SCREW 15/64-28 L=7		*		2.00
30	40009073	NEEDLE BAR FRAME				1.00
31	SS8150822TP	SCREW 15/64-28 L=8				1.00
32	B1404771000	HINGE STUD				1.00
33	CQ252000000	OIL WICK				0.26
34	40009075	POSITION BRACKET				1.00
35	SS5110810SP	SCREW 11/64-40 L=8				2.00
36	B1406761000	OIL FELT, FOR NEEDLE BAR				2.00
37	40009085	OIL FELT UPPER				1.00
38	SS7090520SP	SCREW 9/64-40 L= 4.5				2.00
39	B14027610A0	NEEDLE BAR CONNECTION				1.00
40	SS7090910TP	SCREW 9/64-40 L= 8.5		*		1.00
41	40009086	OIL FELT RETAINER				1.00
42	40009083	NEEDLE BAR				1.00
43	40009093	NEEDLE BAR BOBBIN THREAD GUIDE				1.00
44	SS4080415SP	SCREW 1/8-44 L=4				1.00
45	MDP5JOB1100	NEEDLE DPX5 #11J				1.00
46	B145177100A	NEEDLE BAR THREAD GUIDE	SPECIAL ORDER PARTS FOR SYNT HETIC THREAD			1.00
47	MC2005E0750	NEEDLE 134SES 75	SPECIAL ORDER PARTS			1.00

48	MDP5J0B1400	NEEDLE DPX5 #14J	FOR EXPORT			1.00
49	SS8150920SP	SET-SCREW				1.00
50	MC200500750	NEEDLE 134 NM75	FOR JE			1.00
51	40009077	BUSHING				1.00
52	CQ252000000	OIL WICK				0.25
53	B141423200A	CRANK SLIDE BLOCK	SELECTIVE PARTS			1.00

# OVEREDGING WIDTH ADJUSTING COMPONENTS

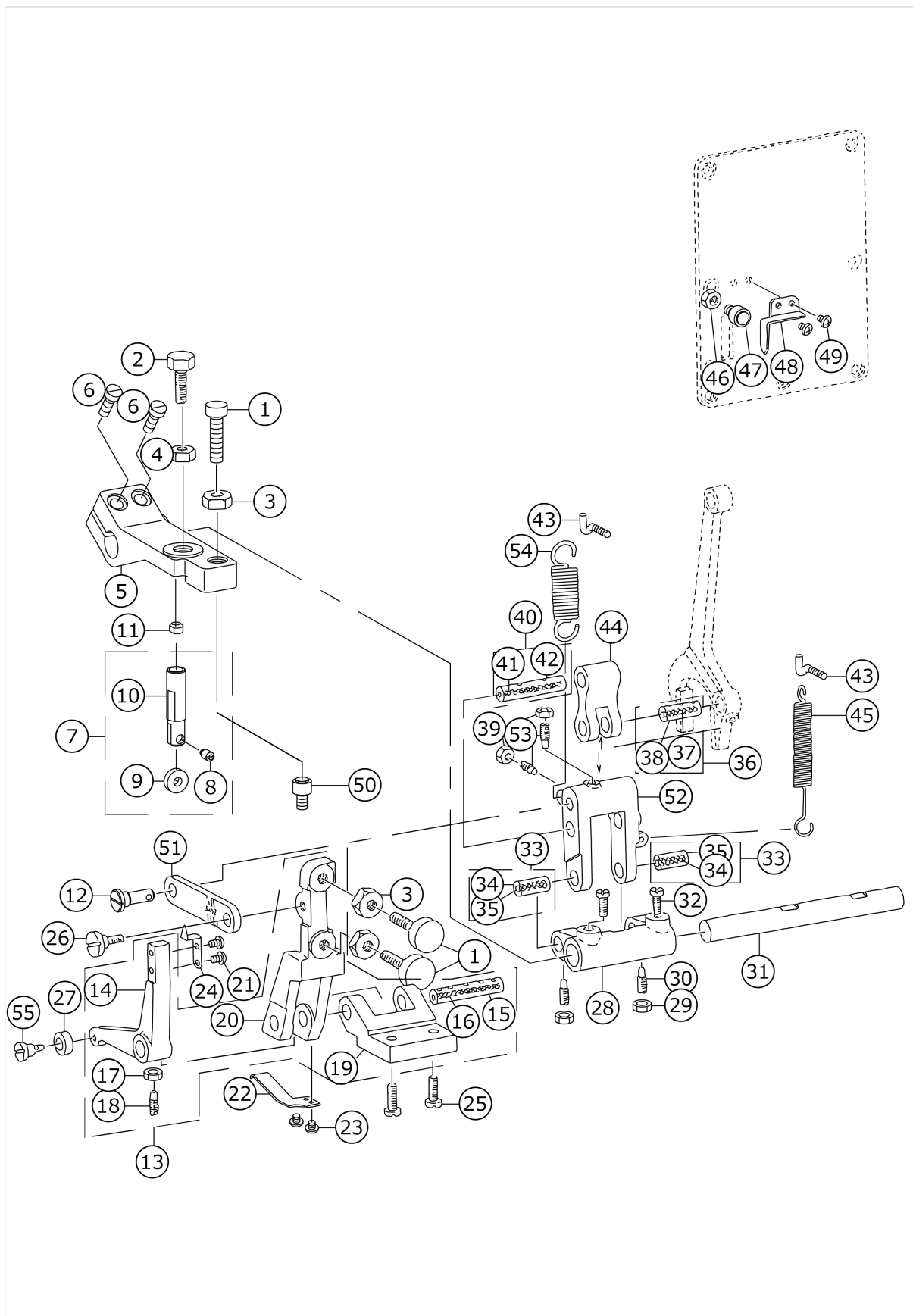

No.	品番	品名	備考	子部品	消耗品	個数
1	40009092	STITCH WIDTH REGULATING SCREW				3.00
2	SS9201973CP	SCREW 5/16-18 L=19				1.00
3	NM6080721SE	NUT M8				1.00
4	NS6200520SP	NUT 5/16-18				3.00
5	40009078	NEEDLE THROW REPOSITIONING LEVER				1.00
6	SS6121210SP	SCREW 3/16-28 L=12				2.00
7	40009107	REPOSITIONING LIVER TRIP PIN ASM.				1.00
8	40009110	PIN		*		1.00
9	40009109	ROLLER		*		1.00
10	40009108	REPOSITIONING LEVER TRIP PIN		*		1.00
11	B1432761000	SWING ARM STOPPER RUBBER				1.00
12	40009106	REGULATING HINGE PIN				1.00
13	40009111	REGULATING LEVER ASM.				1.00
14	40009113	BELL CRANK		*		1.00
15	40009115	REGULATING LEVER SHAFT		*		1.00
16	CQ303000000	OIL WICK		*		0.10
17	NS6110310SP	NUT 11/64-40		*		1.00
18	SS8111251SP	SCREW 11/64-40 L=12.0		*		1.00
19	40009114	REGULATING LEVER BRACKET		*		1.00
20	40009112	REGULATING LEVER		*		1.00
21	SS4080415SP	SCREW 1/8-44 L=4				2.00
22	40009118	SPRING				1.00
23	SS4080415SP	SCREW 1/8-44 L=4				2.00
24	40009117	BARRED WIDTH INDICATOR				1.00
25	SS7151210SP	SCREW 15/64-28 L=12				2.00
26	SD0790432SP	HINGE SCREW D= 7.94 H= 4.3				1.00
27	40009116	ROLLER				1.00
28	B1425771000	BEARING BRACKET				1.00
29	NS6110310SP	NUT 11/64-40				2.00
30	SS8111251SP	SCREW 11/64-40 L=12.0				2.00
31	B1424761000	NEEDLE THROW REPOSITIONING SHAFT				1.00
32	SS7150940SP	SCREW 15/64-28 L=9				2.00
33	B14217610A0	BEARING BRACKET ASM.				2.00
34	CQ252000000	OIL WICK		*		0.10
35	40009105	CONNECTING PIN		*		1.00
36	B14187610A0	CONNECTING FORKED LINK PIN ASM.				1.00
37	CQ252000000	OIL WICK		*		0.10
38	40009103	CONNECTING FORKED LINK PIN		*		1.00
39	NS6110310SP	NUT 11/64-40				2.00
40	B14197610A0	CONNECTING STUD ASM.				1.00
41	CQ252000000	OIL WICK		*		0.10
42	40009104	CONNECTING STUD		*		1.00
43	40009089	SUSPENSION SCREW				2.00
44	26100008	CONNECTING FORKED LINK				1.00
45	B1427771000	SPRING				1.00
46	NS6150310SP	NUT 15/64-28				1.00
47	40009094	SWING ARM STOPPER ASM.				1.00
48	40009081	SEAM WIDTH INDICATOR				1.00
49	SS4080415SP	SCREW 1/8-44 L=4				2.00
50	40009094	SWING ARM STOPPER ASM.				1.00

51	40009102	REGULATING LEVER CONNECTION				1.00
52	26100107	REPOSITIONING LIVER LINK				1.00
53	SS8111251SP	SCREW 11/64-40 L=12.0				2.00
54	B1426771000	SPRING				1.00
55	SD0640471SP	HINGE SCREW D= 6.35 H= 4.7				1.00



# NEEDLE THREAD TRIMMER COMPONENTS

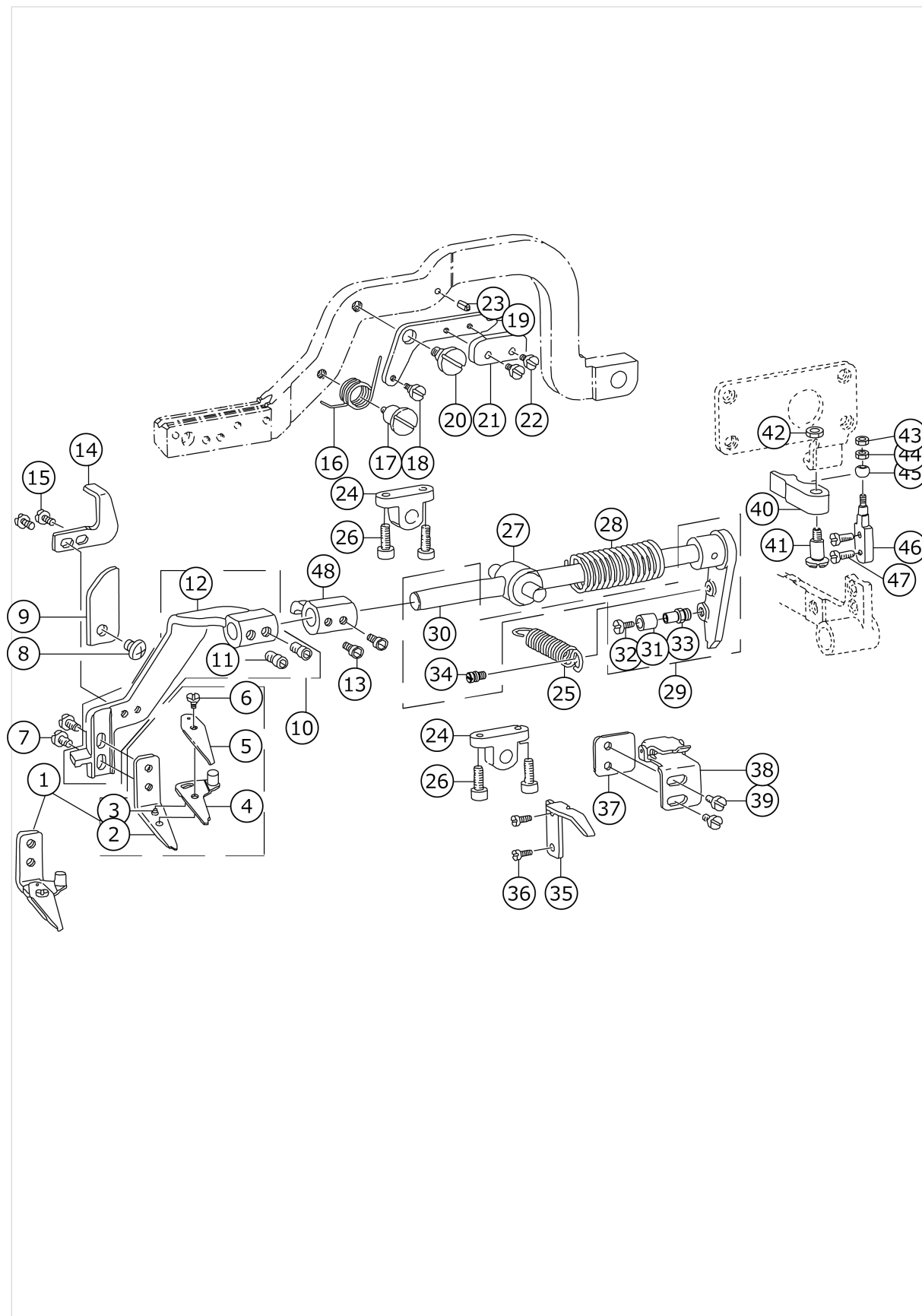

No.	品番	品名	備考	子部品	消耗品	個数
1	B20017710A0	NEEDLE THREAD TRIMMER ASM.				1.00
2	B2001771000	NEEDLE THREAD TRIMMER,LOWER		*		1.00
3	B2005761000	POSITION PIN		*		1.00
4	B20027710A0	NEEDLE THREAD TRIMMER, UPPER		*		1.00
5	B2003771000	NEEDLE THREAD PRESSER SPRING		*		1.00
6	SD0400191TP	HINGE SCREW D=4 H=1.9		*		1.00
7	SS7110510SP	SCREW 11/64-40 L=5				2.00
8	SS4150715SP	SCREW 15/64-28 L=7				1.00
9	40009179	NEEDLE THREAD TRIMMER SHAFT GUIDE				1.00
10	B20637810B0A	THREAD TRIMMER HOLDER ASM.				1.00
11	SM8061002TP	SCREW M6 L=10		*		2.00
12	40009170	THREAD TRIMMER HOLDER ASM.		*		1.00
13	SM8061002TP	SCREW M6 L=10				2.00
14	40008607	LIMITTING PLATE				1.00
15	SS7110840SP	SCREW 11/64-40 L=7.8				2.00
16	40009168	DRAIVING CAM SPRING				1.00
17	40009169	DRAIVING CAM SPRING AXLE				1.00
18	SD0450401SP	HINGE SCREW D= 4.5 H= 4				1.00
19	40008608	DRIVING CAM INSTALING PLATE				1.00
20	SD0790303SP	HINGE SCREW D= 7.94 H= 3.0				1.00
21	40009167	DIFFERENTIAL FEED CAM				1.00
22	SS7090710SP	SCREW 9/64-40 L= 6.8				2.00
23	PS0300102K0	SPRING PIN 3.0X10				1.00
24	B2010771000	BRACKET				2.00
25	B2052781000	THREAD TRIMMER SPRING A				1.00
26	SS6621212TP	SCREW 3/16-32 L=12.0				4.00
27	40009330	THREAD SHAFT GUIDE BASE				1.00
28	40009164	THREAD TRIMMER SPRING B				1.00
29	B20077710B0	NEEDLE THREAD TRIMMER SHAFT ASM.				1.00
30	40009193	NEEDLE THREAD TRIMMER SHAFT		*		1.00
31	26023200	CAM ROLL		*		1.00
32	SS6080610TP	SCREW 1/8-44 L=6		*		1.00
33	40009195	STUD		*		1.00
34	40009196	SUSPENSION SCREW		*		1.00
35	40009186	LATCH PRESSER ARM				1.00
36	SS7090710SP	SCREW 9/64-40 L= 6.8				2.00
37	40009191	SPACER	DEPENDING ON T HE MACHINE FRA ME. 0 ~ 2 SETS OF THIS PART WILL BE USED.			1.00
38	40009181	LOCKING BRACKET LATCH ASM.				1.00
39	SS7110840SP	SCREW 11/64-40 L=7.8				2.00
40	B2030771000	THREAD TRIMMING SHAFT SEGMENT				1.00
41	SD0641003SP	HINGE SCREW D=6.35 H=10				1.00
42	NS6110310SP	NUT 11/64-40				1.00
43	NS6080210SP	NUT 1/8-44				1.00
44	NS6080340SP	NUT 1/8-44				1.00
45	40009188	ROLLER				1.00
46	B2032771000	STUD				1.00

47	SS7110840SP	SCREW 11/64-40 L=7.8				2.00
48	40009160	THREAD TRIMMER HOLDER ASM.				1.00

# BOBBIN THREAD TRIMMER COMPONENTS

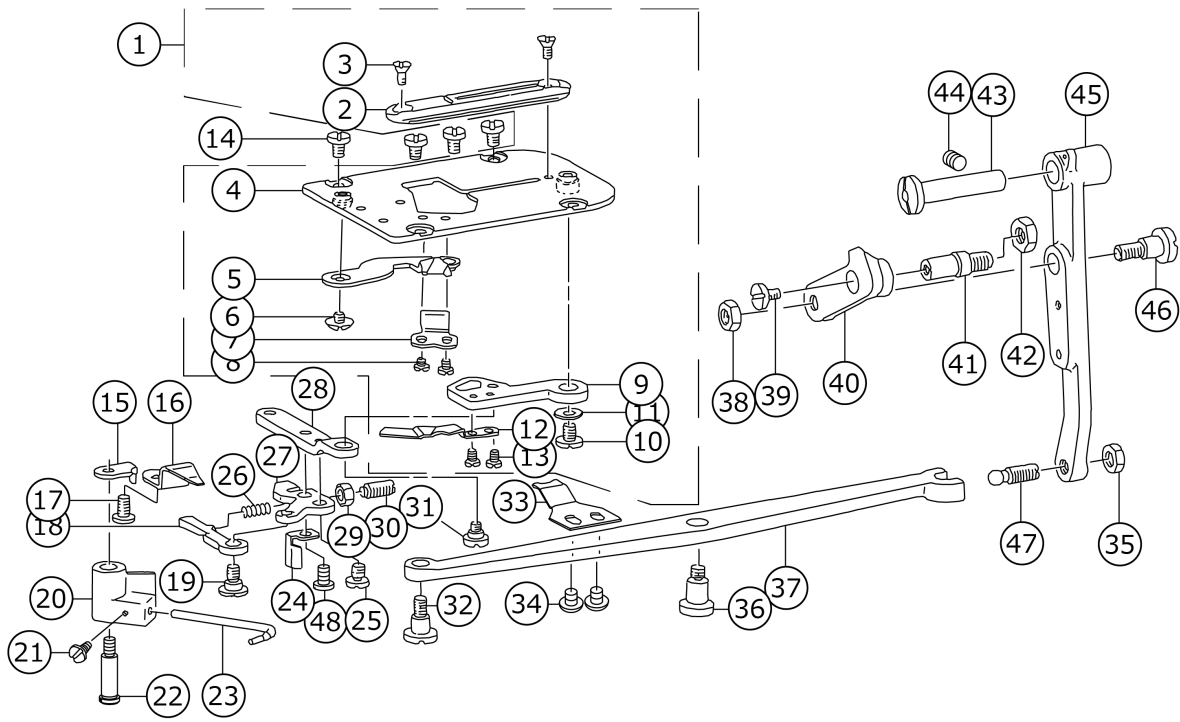

No.	品番	品名	備考	子部品	消耗品	個数
1	B24017710A0	NEEDLE PLATE ASM.				1.00
2	B2402771000	NEEDLE PLATE		*		1.00
3	SS2090510SP	SCREW 9/64-40 L=5		*		2.00
4	B24017710B0	THROAT PLATE BASE ASM.		*		1.00
5	B24067710A0	BOBBIN THREAD TRIMMER BLADE ASM.		*		1.00
6	SS5090320SP	SCREW 9/64-40 L= 3.2		*		1.00
7	B2408771000A	COUNTER KNIFE		*		1.00
8	SS4080310SP	SCREW 1/8-44 L=3.4		*		2.00
9	B2404771000	BOBBIN THREAD TRIMMER LEVER		*		1.00
10	SS7110570SP	SCREW 11/64-40 L= 4.8		*		1.00
11	WP0451016SP	WASHER 4.5X20X1		*		1.00
12	B2405771000	BOBBIN THREAD PULLER		*		1.00
13	SS6090440SP	SCREW 9/64-40 L= 4.0		*		2.00
14	SS6090630TP	SCREW 9/64-40 L=6				4.00
15	40009218	BOBBIN PICKER STOPPER				1.00
16	B2416771000	PRESSER PLATE				1.00
17	SS7110840SP	SCREW 11/64-40 L=7.8				1.00
18	40009220	BOBBIN PICKER PRESSER PLATE				1.00
19	SD0630272SP	HINGE SCREW				1.00
20	B2422771000	BOBBIN PICKER BRACKET				1.00
21	SS7090620TP	SCREW 9/64-40 L=6.1				1.00
22	40009217	BOBBIN PICKER BRACKET SHAFT				1.00
23	40009215	BOBBIN WINDER TRIP LATCH				1.00
24	40009223	SAFETY STOPPER				1.00
25	SS6110610TP	SCREW 11/64-40 L=6				1.00
26	40009222	PRESSER PLATE ADJUSTING SPRING				1.00
27	40009219	PRESSER PLATE MOUNTING BASE				1.00
28	40009214	BOBBIN THREAD TRIMMER LINK				1.00
29	NS6120310SP	NUT 3/16-28				1.00
30	40009221	PRESSER PLATE ADJUSTING SCREW				1.00
31	SD0640321SP	HINGE SCREW D= 6.35 H= 3.2				1.00
32	SD0640602SP	HINGE SCREW D= 6.35 H= 6.0				1.00
33	B2417771000	BOBBIN THREAD GUIDE				1.00
34	SS4090415SP	SCREW 9/64-40 L=4				2.00
35	NS6150310SP	NUT 15/64-28				1.00
36	SD0790602SP	HINGE SCREW D= 7.94 H= 6				1.00
37	40009210	BOBBIN THREAD TRIMMER DRIVING LEVER				1.00
38	NS6150310SP	NUT 15/64-28				1.00
39	SS7110570SP	SCREW 11/64-40 L= 4.8				1.00
40	40009211	CONNECTING LINK				1.00
41	B2414761000	STOP SCREW				1.00
42	NS6680320SP	NUT 9/32-28				1.00
43	B2416761000	HING STUD				1.00
44	SS8150822TP	SCREW 15/64-28 L=8				1.00
45	40009209	BOBBIN THREAD TRIMMER DRIVING ARM				1.00
46	SD0790641SP	HINGE SCREW D= 7.94 H= 6.4				1.00
47	B2412047000	BALL SCREW				1.00
48	SS7110710SP	SCREW 11/64-40 L=7				1.00

# KNIFE BAR COMPONENTS

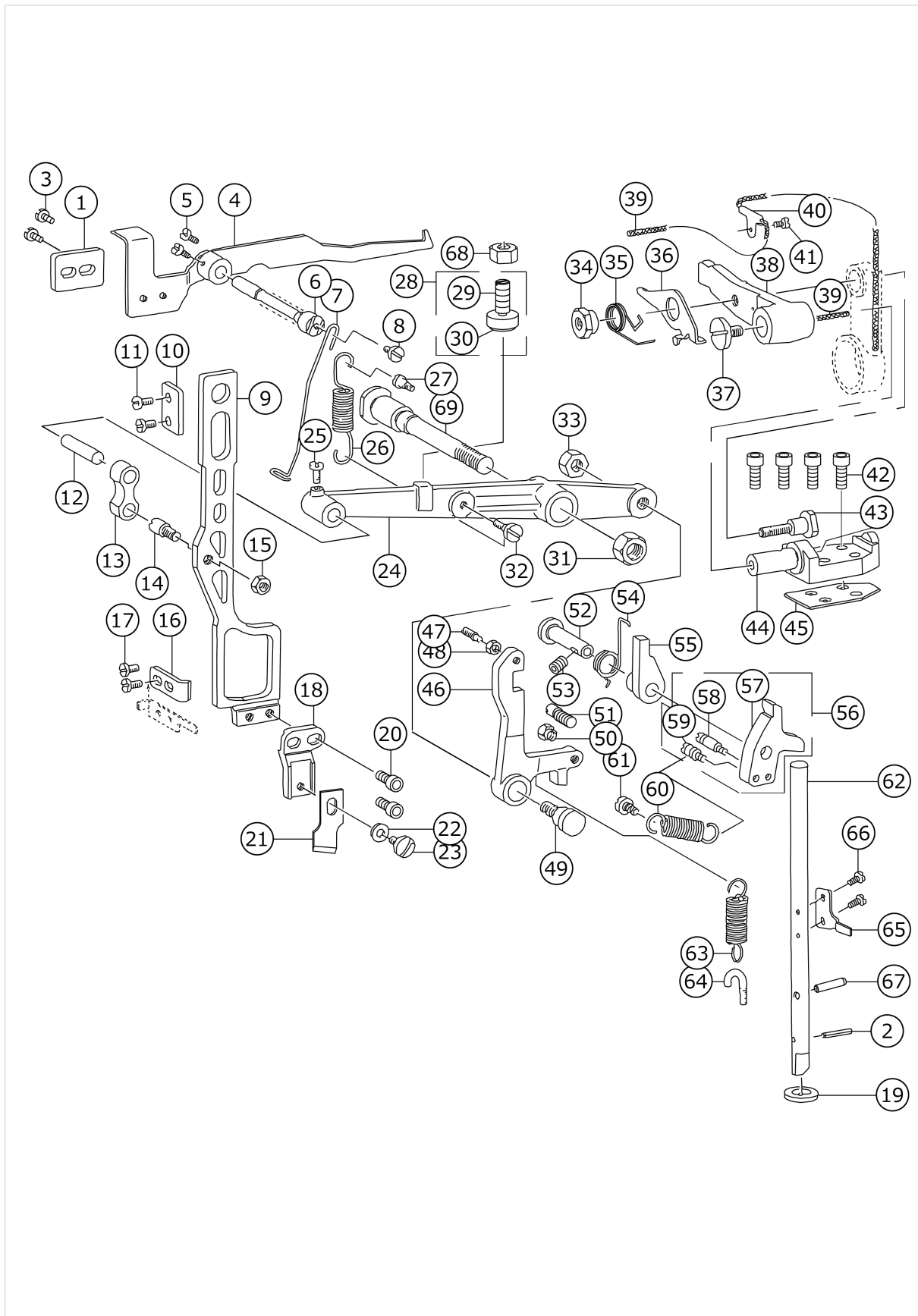

No.	品番	品名	備考	子部品	消耗品	個数
1	40009302	KNIFE STOP LEVER BRACKET				1.00
2	PS0300182KF	SPRING PIN 3X18				1.00
3	SS7110740TP	SCREW 11/64-40 L=7				2.00
4	B2729771000	KNIFE STOP LEVER				1.00
5	SS6110420TP	SCREW 11/64-40 L=4.8				2.00
6	40009300	KNIFE STOP LEVER HINGE STUD				1.00
7	B2731761000	THREAD CHECK WIRE				1.00
8	SS7110840SP	SCREW 11/64-40 L=7.8				1.00
9	B2702771000A	KNIFE BAR				1.00
10	40009280	KNIFE ROD GUIDE PLATE A	SELECTIVE PARTS			1.00
11	SS7110710SP	SCREW 11/64-40 L=7				2.00
12	40009290	HINGE STUD				1.00
13	B2706761000	KNIFE BAR CONNECTING LINK				1.00
14	B2705761000	HINGE SCREW				1.00
15	NS6660430SP	NUT 1/4-40				1.00
16	40009284	KNIFE BAR POSITIONING BRACKET	SELECTIVE PARTS			1.00
17	SS7110840SP	SCREW 11/64-40 L=7.8				2.00
18	B2701761000	KNIFE HOLDER				1.00
19	B2740771000	THRUST WASHER				1.00
20	SM6061202TP	SCREW M6 L=12				2.00
21	B2702047L00A	KNIFE 1/2	THE SIZE OF THE BUTTONHOLE VARIES ACCORDING TO THE KNIFE ,SO FOR FURTHER DETAILS PLEASE REFER TO PAGE 39,22-(2).			1.00
22	WP0501016SD	WASHER 5X10.5X1				1.00
23	SS7620750SP	SCREW 3/16-32 L= 6.5				1.00
24	B2751781000	KNIFE BAR DRIVING LEVER				1.00
25	SS7110810SP	SCREW 11/64-40 L= 8.0				1.00
26	B2710771000	SPRING				1.00
27	SD0550501SP	HINGE SCREW D=5.5 H=5				1.00
28	40009264	KNIFE BAR STOPPER ASM.				1.00
29	40009265	KNIFE BAR STOPPER		*		1.00
30	40009266	STOPPER BUSH		*		1.00
31	NS6740510SP	NUT 3/8-28				1.00
32	SD0790201SD	HINGE SCREW D=7.9 H=2.0				1.00
33	NS6700540SP	NUT 5/16-24				1.00
34	40009294	KNIFE BAR DRIVING CRANK NUT				1.00
35	B2718761000	TENSION SPRING				1.00
36	40009292	LATCH				1.00
37	SS7161040SP	SCREW 1/4-24 L= 9.5				1.00
38	40009291	KNIFE BAR DRIVING CRANK				1.00
39	CQ252000000	OIL WICK				0.40
40	B3537122000	OIL WICK HOLDER				1.00
41	SS4090610SP	SCREW 9/64-40 L=6				1.00

42	SM6062002TP	SCREW M6 L=20				4.00
43	SD1110905TH	HINGE SCREW D=11.11 H= 9.0				1.00
44	26105809	KNIFE BAR DRIVING CRANK SHAFT				1.00
45	40009304	SPACER	SELECTIVE PARTS			1.00
46	40009441	KNIFE BAR DRIVING LEVER BELL CRANK				1.00
47	SS8111610SP	SCREW 11/64-40 L=15.5				1.00
48	NS6110310SP	NUT 11/64-40				1.00
49	SD1110905TH	HINGE SCREW D=11.11 H= 9.0				1.00
50	40009277	HOOK PIN NUT				1.00
51	40009278	HOOK PIN				1.00
52	B2416761000	HING STUD				1.00
53	SS8150822TP	SCREW 15/64-28 L=8				1.00
54	B2725761000	TENSION SPRING				1.00
55	B2724761000	RATCHET PAWL (B)				1.00
56	B27237610A0A	HOOK DIFFERENTIAL CLICK A ASM.				1.00
57	B2723761000A	HOOK DIFFERENTIAL CLICK A		*		1.00
58	10120004	SPRING SUSPENSION		*		1.00
59	B1110280000	THREAD CUTTING LINK SPRING RACK		*		1.00
60	B2726761000A	TENSION SPRING				1.00
61	SD0530221SP	HINGE SCREW D= 5.3 H= 2.2				1.00
62	40009270	DRIVING ROD				1.00
63	40009299	TENSION SPRING				1.00
64	40009305	SUSPENSION SCREW				1.00
65	40009274	FINGER				1.00
66	SS7090710SP	SCREW 9/64-40 L= 6.8				2.00
67	40009303	POSITIONING PIN (B)				1.00
68	NS6200520SP	NUT 5/16-18				1.00
69	B2709771000	KNIFE BAR DRIVING LEVER SHAFT				1.00



# FEED CAM & TRIPPING SEGMENT COMPONENTS

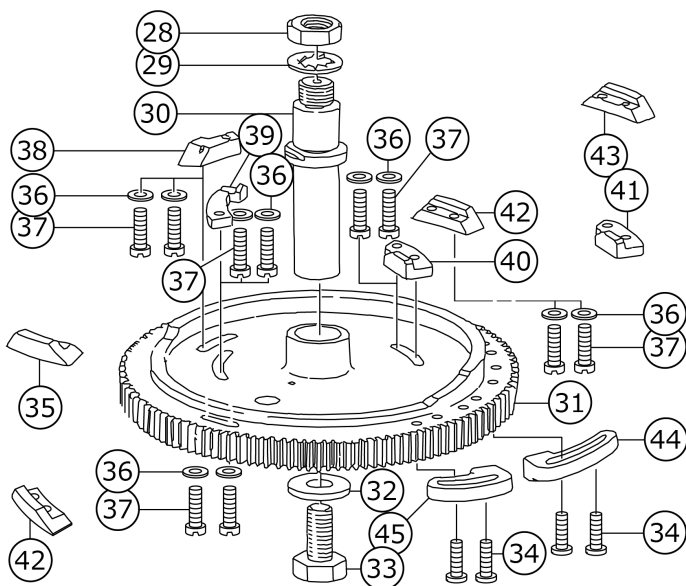
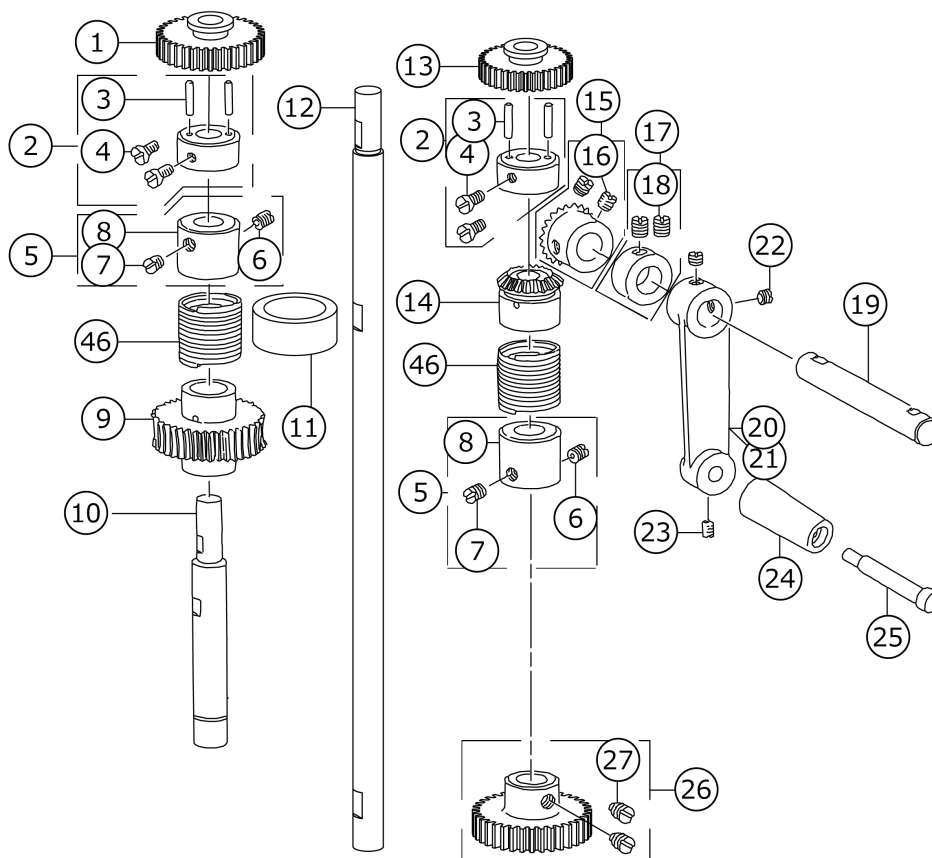

No.	品番	品名	備考	子部品	消耗品	個数
1	B2935761000	SPUR GEAR (152)				1.00
2	B29167610A0	SPUR GEAR BUSHING ASM.				2.00
3	B2917761000	SPUR GEAR BUSHING PIN		*		4.00
4	SS7120910TP	SCREW 3/16-28 L=9		*		4.00
5	B29137610A0	CLUTCH COLLAR ASM.				2.00
6	SS8660610TP	SCREW 1/4-40 L=6		*		1.00
7	SS8660410SP	SCREW 1/4-40 L= 4.2		*		1.00
8	40009314	CLUTCH COLLAR		*		1.00
9	B2919761000	FEED CAM DRIVING WORM WHEEL				1.00
10	40009316	FEED CAM DRIVING WORM WHEEL SHAFT				1.00
11	B3542771000	OIL FELT				1.00
12	26107201	CAM DRIVING STUD				1.00
13	B2934761000	SPUR GEAR (123)	FOR EXCHANGING GEARS, PLEASE REFER TO PAGE 39,22-(1).			1.00
14	B2915761B00	HANDLE CRANK BEVEL GEAR, LEFT				1.00
15	B2915761AA0	HANDLE CRANK BEVEL GEAR ASM.,				1.00
16	SS8660610TP	SCREW 1/4-40 L=6		*		2.00
17	CS111101DSH	THRUST COLLAR ASM. D=11.11 W=10				1.00
18	SS8660530TP	SCREW 1/4-40 L= 4.5		*		2.00
19	40009318	HANDLE CRANK SHAFT				1.00
20	B2923761000	HANDLE CRANK				1.00
21	40009319	HANDLE CRANK	FOR URBAN WHITE			1.00
22	SS8150510TP	SCREW 15/64-28 L= 4.7				2.00
23	SS8620610SP	SCREW 3/16-32 L=6				1.00
24	40009320	HANDLE				1.00
25	40009321	HANDLE SHAFT				1.00
26	B29107610A0	FEED CAM DRIVING GEAR ASM.				1.00
27	SS8660610TP	SCREW 1/4-40 L=6		*		2.00
28	NM6120001CP	NUT M12				1.00
29	B2909761000	THRUST WASHER				1.00
30	40009312	FEED CAM SHAFT				1.00
31	B290177100C	FEED CAM				1.00
32	WP0982616SP	WASHER 9.8X24.0X2.6				1.00
33	SS9241513CP	SCREW 3/8-18 L=15				1.00
34	SS7111410TP	SCREW 11/64-40 L=14				4.00
35	B2902761B00	BAR TRIPPING SEGMENT NO.2 (B)	SPECIAL ORDER PARTS FOR 80% BARTACKING			1.00
36	WP0480856SP	WASHER 4.8X8.4X0.8				10.00
37	SS6111610SP	SCREW 11/64-40 L=16				10.00
38	B2904771000	KNIFE TRIPPING SEGMENT				1.00
39	40009309	TENSION RELEASE TRIPPING SEGMENT 1				1.00
40	40009310	TENSION RELEASE TRIPPING SEGMENT 2				1.00
41	B2906761B00	TRIPPING SEGMENT NO.2	SPECIAL ORDER PARTS FOR LESS THAN 80 STITC HES			1.00

42	26100909	BAR TRIPPING SEGMENT NO.1				2.00
43	B2903761B00	BAR TRIPPING SEGMENT NO.2 (B)	SPECIAL ORDER PARTS FOR 80% BARTACKING			1.00
44	26100800	LOW-SPEED CAM				1.00
45	26104604	STOPPER CAM				1.00
46	B2914761000	CLUTCH SPRING				2.00

# STOP-MOTION COMPONENTS

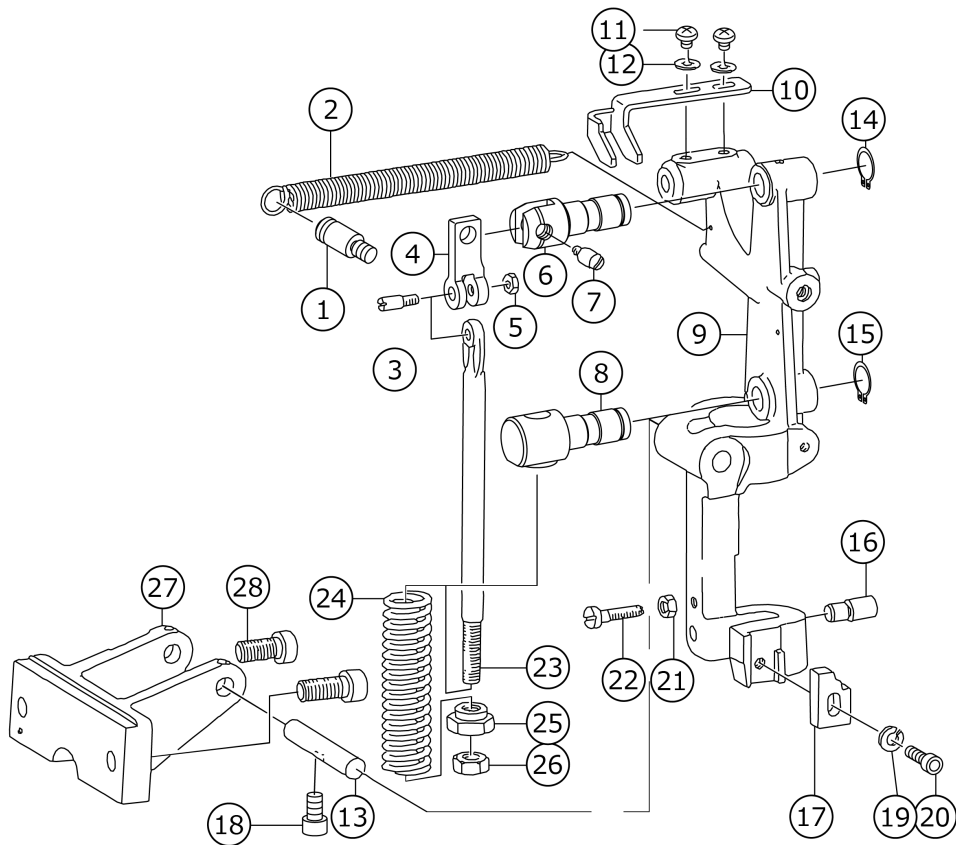

No.	品番	品名	備考	子部品	消耗品	個数
1	26212308	BELT COVER SETSCREW				1.00
2	B2653771000	TENSION SPRING				1.00
3	B2613232000	STOP LINK ROD HINGE SCREW				1.00
4	26106807	UPPER SHAFT STOPPER				1.00
5	NS6620310SP	NUT 3/16-32				1.00
6	26107300	STOPPER PIN				1.00
7	B2611232000	STOP LINK CONNECTING SCREW				1.00
8	26107508	STOP LINK ROD HINGE STUD				1.00
9	B2604771000B	STOP MOTION LEVER				1.00
10	40009228	BELT SHIFTER				1.00
11	SS4150715SP	SCREW 15/64-28 L=7				2.00
12	WP0650876SD	WASHER 6.5X13X0.8				2.00
13	40009254	INSTALLING BASE PIN				1.00
14	RC1200001KP	C-SHAPED SNAP RING				1.00
15	RC1200001KP	C-SHAPED SNAP RING				1.00
16	B2648232000	STOP PIN				1.00
17	40009229	LATCH (A)				1.00
18	SM6061602TP	SCREW M6 L=16				1.00
19	WS0610002KP	SPRING WASHER				1.00
20	SM6062002TP	SCREW M6 L=20				1.00
21	NS6150430SP	NUT 15/64-28				1.00
22	SS6153040SP	SCREW 15/64-28 L=30				1.00
23	40009249	STOP LINK ROD				1.00
24	40009251	STOP LINK ROD PRESSURE SPRING				1.00
25	40009252	SPRING SUPPORT NUT				1.00
26	NS6240630SP	NUT 3/8-18				1.00
27	B2601761000A	STOP MOTION LEVER BRACKET				1.00
28	SM6102002TP	SCREW M10 L=20				2.00

# TRIPPING LEVER COMPONENTS

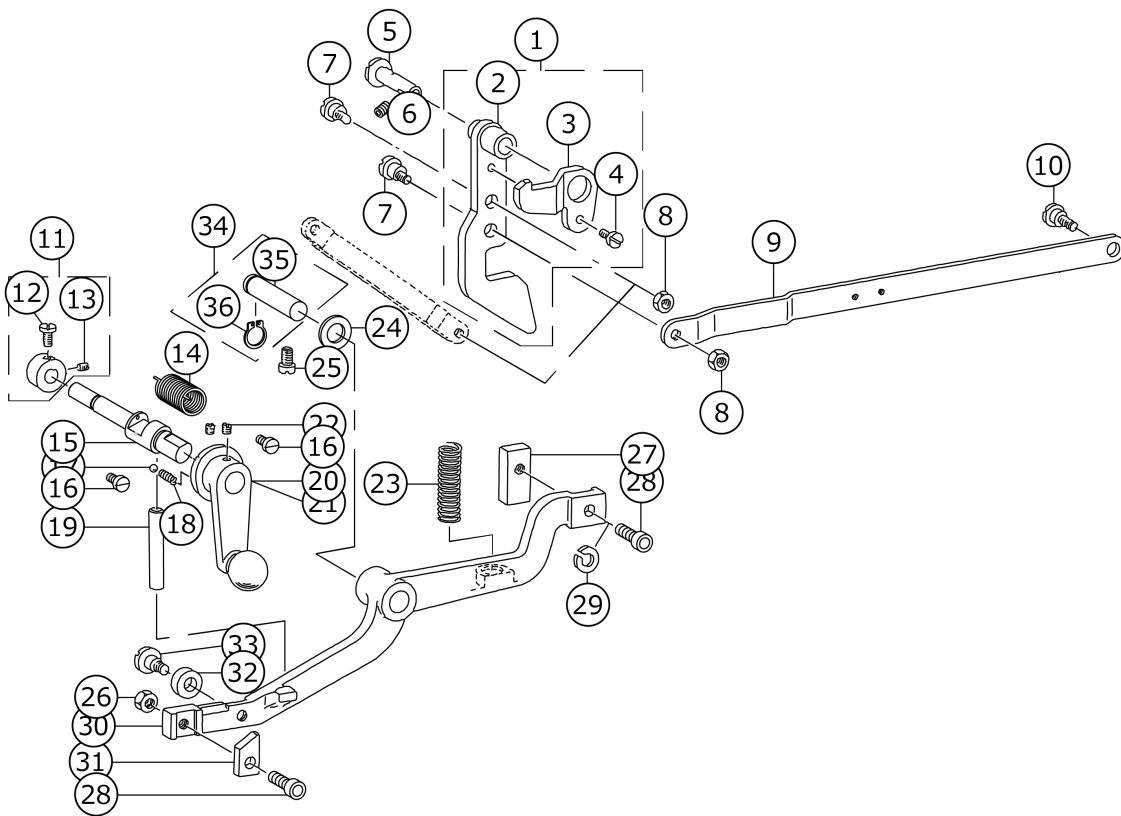

No.	品番	品名	備考	子部品	消耗品	個数
1	40009255	STARTING LINK COMPL.				1.00
2	40009256	STARTING LINK ASM.		*		1.00
3	40009259	SAFETY BASE		*		1.00
4	SS7110710SP	SCREW 11/64-40 L=7		*		1.00
5	B2416761000	HING STUD				1.00
6	SS8150822TP	SCREW 15/64-28 L=8				1.00
7	40009233	HINGE SCREW				2.00
8	NS6150310SP	NUT 15/64-28				2.00
9	40009245	STARTING LINK DRIVING ROD				1.00
10	SD0790451SP	HINGE SCREW D= 7.94 H= 4.5				1.00
11	CS079101BSH	THRUST COLLAR ASM. D=7.94 W=10				1.00
12	SS7110740TP	SCREW 11/64-40 L=7		*		1.00
13	SS8110510SP	SCREW 11/64-40 L=5		*		1.00
14	40009247	CRANK SHAFT TENSION SPRING				1.00
15	40009241	HAND STOP CRANK SHAFT				1.00
16	SS6111010TP	SCREW 11/64-40 L= 9.5				2.00
17	B2608761000	HAND STOP CRANK SHAFT BALL				1.00
18	B2611761000	CRANK SHAFT PRESSURE SPRING				1.00
19	40009242	HAND STOP ROD B	SELECTIVE PARTS			1.00
20	B26107610A0	HAND STOP CRANK ASM.				1.00
21	B26107610AA	HAND STOP CRANK ASM.	FOR URBAN WHITE			1.00
22	SS8150510TP	SCREW 15/64-28 L= 4.7				2.00
23	B2617771000	TRIPPING LEVER TENSION SPRING				1.00
24	40009262	WASHER				1.00
25	SS7150940SP	SCREW 15/64-28 L=9				1.00
26	NM6060001CP	NUT M6				1.00
27	40009238	LATCH (B)				1.00
28	SM6062002TP	SCREW M6 L=20				2.00
29	WS0610002KP	SPRING WASHER				1.00
30	B2651781000A	TRIPPING LEVER				1.00
31	40009243	TRIPPING DOG				1.00
32	40009116	ROLLER				1.00
33	SD0640471SP	HINGE SCREW D= 6.35 H= 4.7				1.00
34	40009260	TRIPPING LEVER HINGE PIN ASM.				1.00
35	40009261	TRIPPING LEVER HINGE PIN		*		1.00
36	RC1021011KP	RETAINING RING 10.2		*		1.00

# LIFTING LEVER & BOBBIN WINDER COMPONENTS

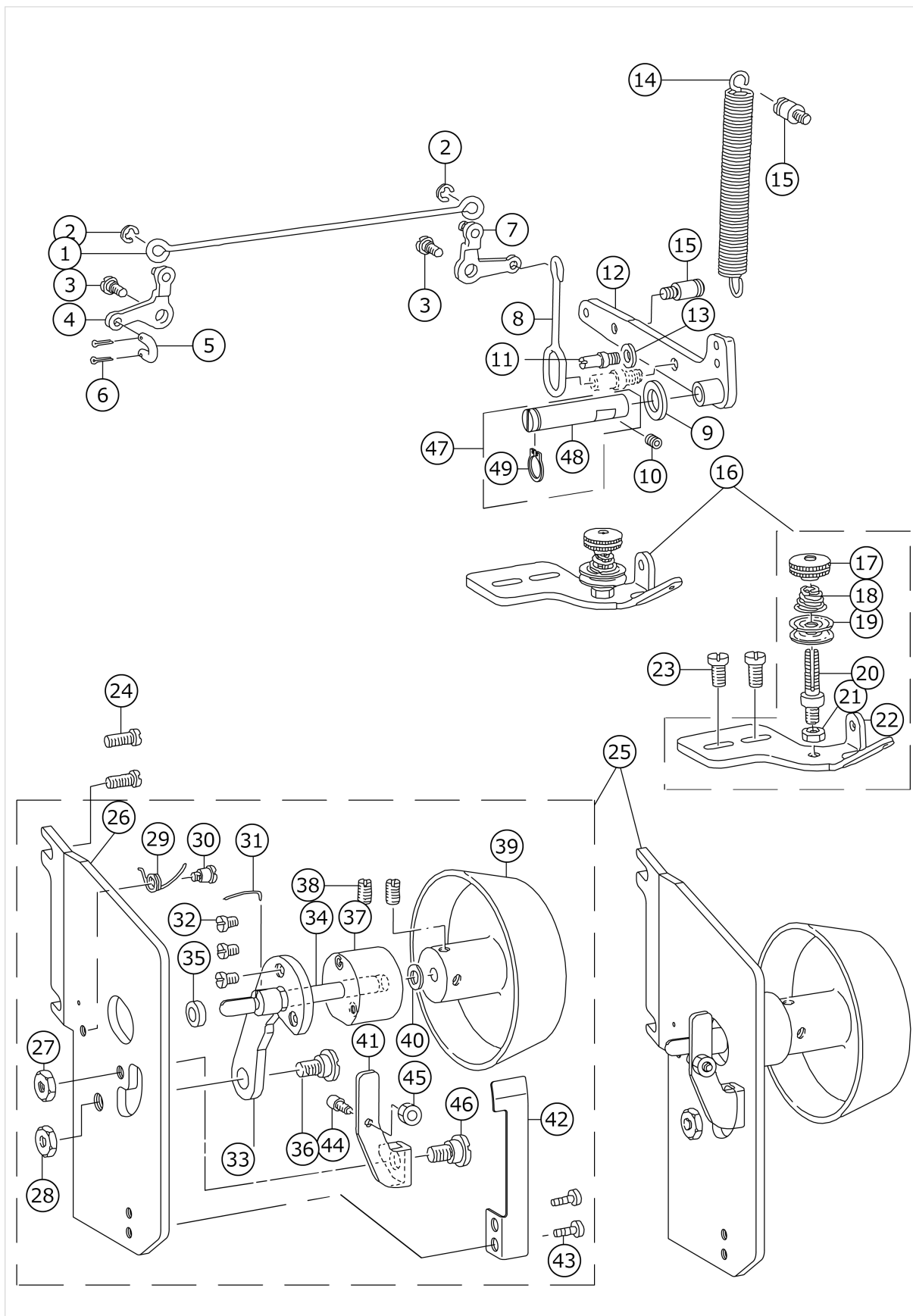



No.	品番	品名	備考	子部品	消耗品	個数
1	B3404771000	PRESSER BAR LIFTING ROD				1.00
2	RE0500000K0	E-RING				2.00
3	SD0720331SP	HINGE SCREW D= 7.24 H= 3.3				2.00
4	B34027710A0	LEVER ASM., FRONT				1.00
5	B3406761000	LINK				1.00
6	PD02010000B	SPLIT PIN				2.00
7	B34087710A0	LEVER ASM., REAR				1.00
8	B3403761000	PRESSER BAR LIFTING ROD				1.00
9	40009262	WASHER				1.00
10	SS8150822TP	SCREW 15/64-28 L=8				1.00
11	40009357	LIFTING LEVER STOPPER				1.00
12	26106658	LIFTING LEVER ASM.				1.00
13	WP0740516SP	WASHER 7.4X11.8X0.5				1.00
14	B3451781000	PRESSER FOOT LIFTING SPRING				1.00
15	26212308	BELT COVER SETSCREW				2.00
16	40009348	BOBBIN WINDER TENSION ASM.				1.00
17	26216507	BOBBIN WINDER TENSION NUT		*		1.00
18	26216606	BOBBIN WINDER TENSION SPRING		*		1.00
19	22945802	THREAD TENSION DISK		*		2.00
20	26216705	BOBBIN WINDER TENSION POST		*		1.00
21	26216705	BOBBIN WINDER TENSION POST		*		1.00
22	40009349	BOBBIN WINDER TENSION		*		1.00
23	SS7110840SP	SCREW 11/64-40 L=7.8				4.00
24	SS7110840SP	SCREW 11/64-40 L=7.8				2.00
25	26103150	BOBBIN WINDER ASM.				1.00
26	26103101	BOBBIN WINDER BRACKET		*		1.00
27	26104208	NUT		*		1.00
28	26104307	NUT		*		1.00
29	26103705	BOBBIN WINDER SPRING		*		1.00
30	SD0450401SP	HINGE SCREW D= 4.5 H= 4		*		1.00
31	26103903	BOBBIN STOP SPRING		*		1.00
32	SS6090620SP	SCREW 9/64-40 L=6		*		3.00
33	26103309	PULLEY SHAFT BASE		*		1.00
34	26103507	BOBBIN WINDER SHAFT		*		1.00
35	26104109	COLLAR		*		1.00
36	SD0790433TP	HINGE SCREW D= 7.94 H= 4.3		*		1.00
37	26103408	BOBBIN WINDER SHAFT BUSHING		*		1.00
38	SS8120740SP	SCREW 3/16-28 L=7		*		2.00
39	26103200	BOBBIN WINDER DRIVING PULLEY		*		1.00
40	WP0651056SD	WASHER 6.5X11X1		*		1.00
41	26103606	BOBBIN WINDER TRIP LATCH		*		1.00
42	26103804	BOBIN GUIDE SPRING		*		1.00
43	SS7090520SP	SCREW 9/64-40 L= 4.5		*		2.00
44	26104000	ADJUSTING SCREW		*		1.00
45	26104505	NUT		*		1.00
46	26104406	BOBBIN GUIDE SHAFT		*		1.00
47	40009260	TRIPPING LEVER HINGE PIN ASM.				1.00
48	40009261	TRIPPING LEVER HINGE PIN		*		1.00
49	RC1021011KP	RETAINING RING 10.2		*		1.00

# THREAD TENSION COMPONENTS

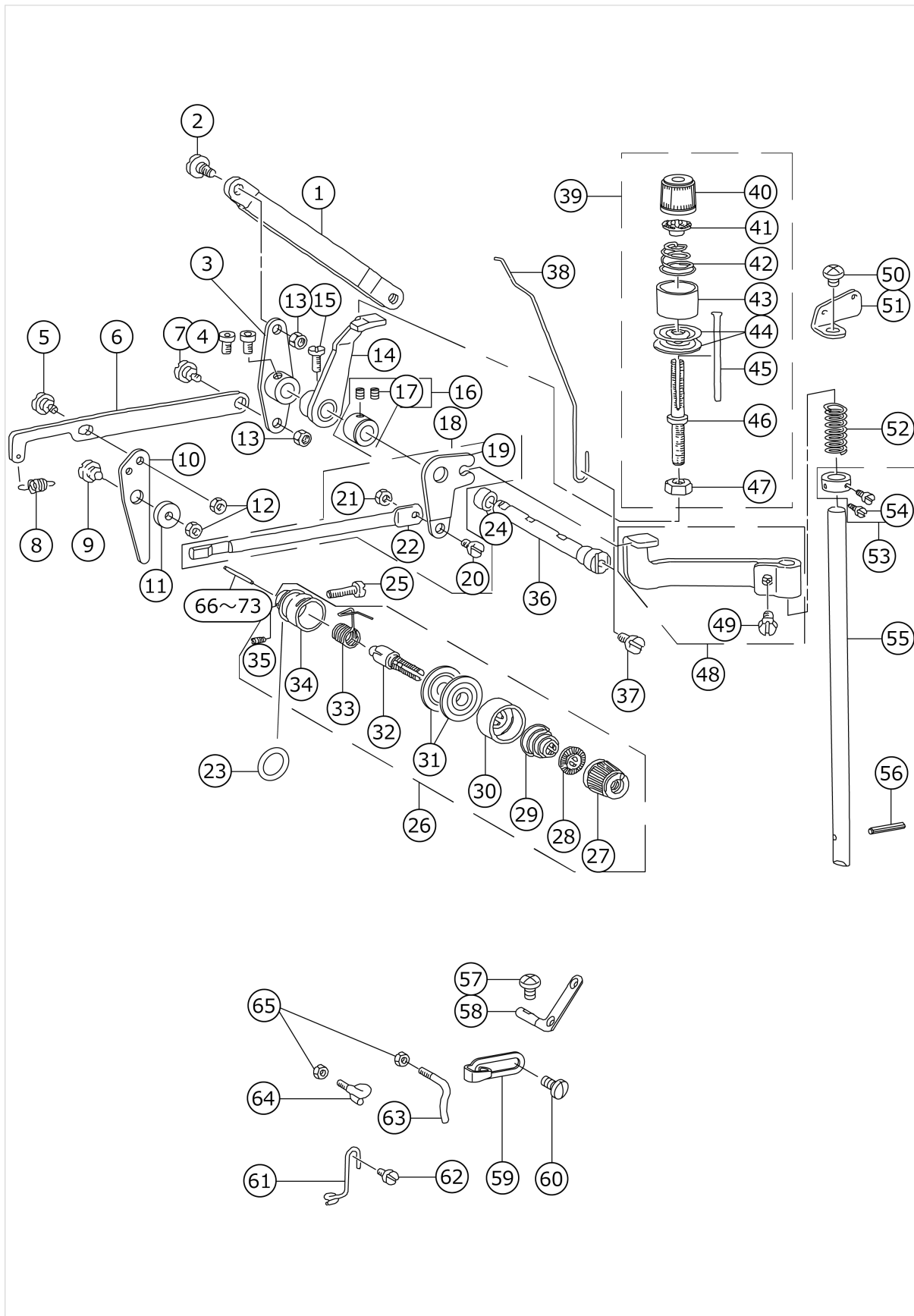

No.	品番	品名	備考	子部品	消耗品	個数
1	40009325	TENSION RELEASE LINK				1.00
2	SD0640391TP	HINGE SCREW D= 6.35 H= 3.9				1.00
3	B3152781000	TENSION RELEASE LEVER				1.00
4	SS6660712TP	SCREW 1/4-40 L= 7.0				2.00
5	SD0640241SP	HINGE SCREW D= 6.35 H= 2.4				1.00
6	40009165	BLOCKING LINK				1.00
7	SD0640391TP	HINGE SCREW D= 6.35 H= 3.9				1.00
8	B2056781000	BLOCKING ARM SPRING				1.00
9	SD0790311TP	HINGE SCREW D= 7.94 H= 3.1				1.00
10	40008611	BLOCKING ARM				1.00
11	40008609	BLOCKING ARM BRACKET				1.00
12	NS6110310SP	NUT 11/64-40				2.00
13	NS6120310SP	NUT 3/16-28				1.00
14	B3116771000	TENSION RELEASE LEVER				1.00
15	SS7621040SP	SCREW 3/16-32 L= 9.5				1.00
16	CS079101DSH	THRUST COLLAR ASM. D=7.94 W=10				1.00
17	SS8110520TP	SCREW 11/64-40 L= 4.5		*		2.00
18	40009327	TENSION RELEASE LEVER CRANK ASM.				1.00
19	40009328	TENSION RELEASE CRANK NO.2		*		1.00
20	SD0500301SP	HINGE SCREW D= 5 H= 3		*		1.00
21	NS6090310SP	NUT 9/64-40		*		1.00
22	40009329	TENSION RELEASE ROD		*		1.00
23	RO095200100	RUBBER RING				1.00
24	B310777100B	TENSION RELEASE LEVER COLLAR NO.2				1.00
25	SS6111610SP	SCREW 11/64-40 L=16				1.00
26	B31107710A0	TENSION CONTROLLER NO.2 ASM.				1.00
27	11956703	THREAD TENSION KNOB, RED		*		1.00
28	B3112704000	TENSION SPRING BUSHING		*		1.00
29	B3101804000	TENSION SPRING, RED		*		1.00
30	B3107804000	THREAD TENSION DISK PRESSER		*		1.00
31	B3126012000	THREAD TENSION DISK		*		2.00
32	B3111761000	TENSION POST NO.3		*		1.00
33	B3112761000	THREAD TAKE-UP SPRING		*		1.00
34	B3110771000	TENSION POST SOCKET		*		1.00
35	SS8090670SP	SCREW 9/64-40 L= 5.5		*		1.00
36	B3106771000	TENSION RELEASE LEVER SHAFT				1.00
37	SS7110840SP	SCREW 11/64-40 L=7.8				1.00
38	B3120771000	THREAD PULLING WIRE				1.00
39	B31037710A0	TENSION CONTROLLER NO. 1 ASM.				1.00
40	11956703	THREAD TENSION KNOB, RED		*		1.00
41	B3112704000	TENSION SPRING BUSHING		*		1.00
42	B2017372000	TENSION SPRING NO.1		*		1.00
43	B3107804000	THREAD TENSION DISK PRESSER		*		1.00
44	B3126012000	THREAD TENSION DISK		*		2.00
45	B3103761000	TENSION RELEASE PIN NO.2		*		1.00
46	B2019372000	TENSION POST NO.2		*		1.00
47	NS6160520SP	NUT 1/4-24		*		1.00
48	B31027710A0	TENSION RELEASE ARM ASM.				1.00
49	SS9660940TP	SCREW 1/4-40 L=8.5		*		1.00
50	SS4150715SP	SCREW 15/64-28 L=7				1.00

51	B1111232000	THREAD GUIDE PLATE				1.00
52	B3117771000	SPRING				1.00
53	CS0790720TH	THRUST COLLAR ASM.				1.00
54	SS7090720TP	SCREW 9/64-40 L=6.8		*		2.00
55	40009339	TENSION RELEASE ROD				1.00
56	PS0300182KF	SPRING PIN 3X18				1.00
57	SS4110715SP	SCREW 11/64-40 L=7				1.00
58	22920706	TWO EYELET				1.00
59	40009037	TAKE-UP THREAD GUIDE				1.00
60	SS7090710SP	SCREW 9/64-40 L= 6.8				1.00
61	40009340	NEEDLE BAR THREAD GUIDE				1.00
62	SS7110840SP	SCREW 11/64-40 L=7.8				1.00
63	B3118771000	TENSION THREAD GUIDE, NO.2				1.00
64	B3114771000	THREAD GUIDE				1.00
65	NS6090310SP	NUT 9/64-40				2.00
66	B3118552D00	TENSION RELEASE PIN, NO.2	SELECTIVE PARTS			1.00
67	B3118552A00	TENSION RELEASE PIN A	SELECTIVE PARTS			1.00
68	B3118552B00	TENSION RELEASE PIN B	SELECTIVE PARTS			1.00
69	B3118552C00	TENSION RELEASE PIN C	SELECTIVE PARTS			1.00
70	22920904	TENSION RELEASE PIN	SELECTIVE PARTS			1.00
71	B3118552F00	TENSION RELEASING PIN	SELECTIVE PARTS			1.00
72	B3118552G00	TENSION RELEASE PIN	SELECTIVE PARTS			1.00
73	B3118552H00	THREAD RELEASE PIN	SELECTIVE PARTS			1.00

# LUBRICATION MECHANISM COMPONENTS

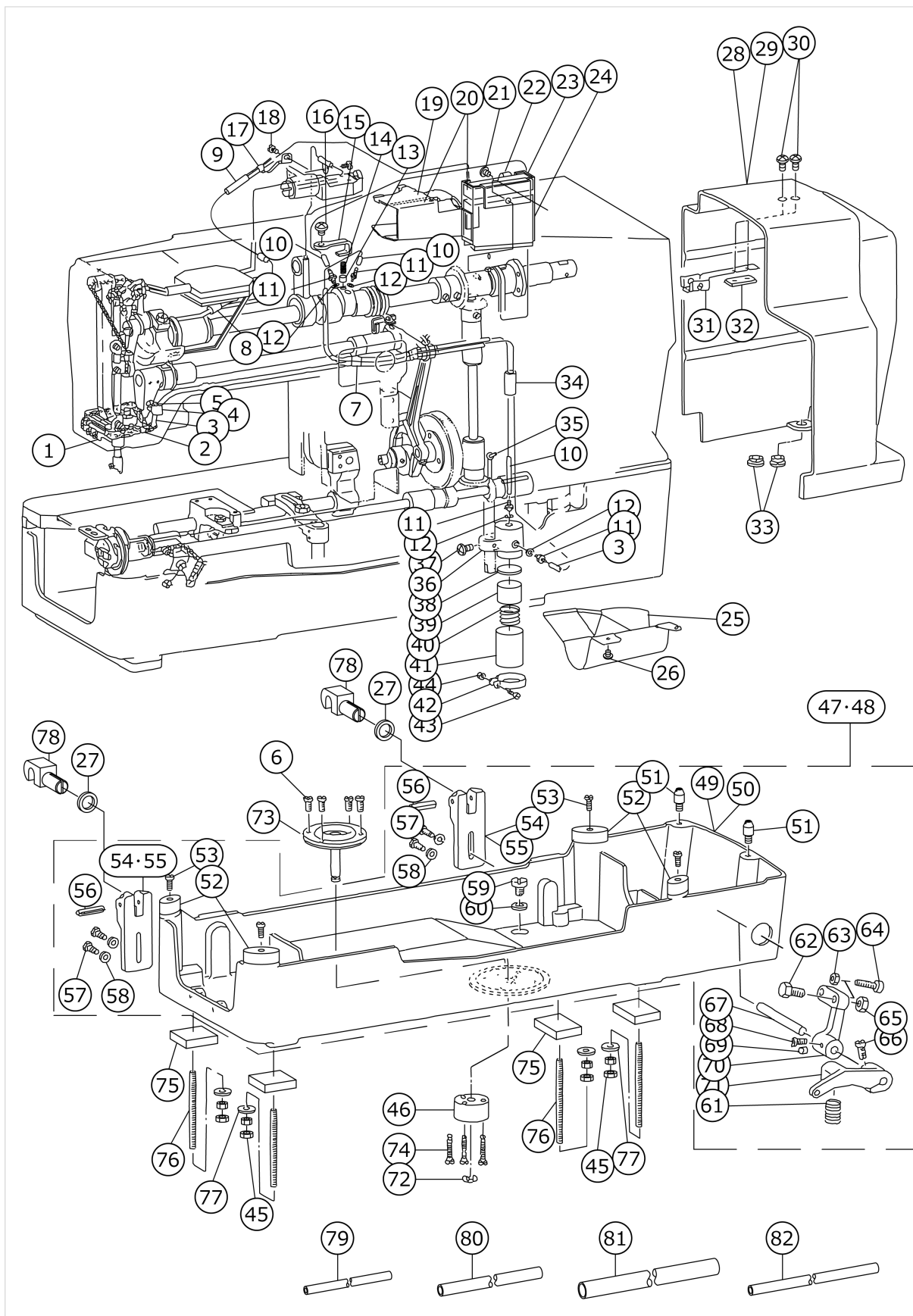

No.	品番	品名	備考	子部品	消耗品	個数
1	40009374	OIL FELT HOLDER				1.00
2	B3549771000	OIL RETURN FELT (A)				1.00
3	B3568771000	OIL RETURN TUBE				1.00
4	B3571771000	PIPE HOLDER				1.00
5	SS7110710SP	SCREW 11/64-40 L=7				1.00
6	SS7110910TP	SCREW 11/64-40 L= 8.5	ACCESSORY PARTS			4.00
7	40009369	PIPE GUIDE (A)				1.00
8	BP600000000	VINYL PIPE				0.10
9	BP500000000	VINYL PIPE				0.05
10	BP300000000	VINYL PIPE				0.55
11	SQ1110402MZ	CONNECTING SCREW				4.00
12	B3534012000	GASKET				4.00
13	B3534155000	PLUNGER				1.00
14	B1214038000	PLUNGER SPRING				1.00
15	40009361	THRUST PLATE				1.00
16	SS4150715SP	SCREW 15/64-28 L=7				1.00
17	40009373	OIL FELT GUIDE				1.00
18	SS7110710SP	SCREW 11/64-40 L=7				1.00
19	B3560771000	OIL FELT				1.00
20	B11357710A0	OIL PAN ASM.				1.00
21	SS4110515SP	SCREW 11/64-40 L=5				1.00
22	B3561771000	OIL UNWOVEN CLOTH				1.00
23	B1148771000	OIL FELT				1.00
24	B1147771000	OIL FELT				1.00
25	B3563771000A	OIL SHIELD				1.00
26	SS4110515SP	SCREW 11/64-40 L=5				2.00
27	B1124771000	CUSHION				2.00
28	B1154781000	BELT GUARD				1.00
29	B115478100A	BELT GUARD	FOR URBAN WHITE			1.00
30	SS4110815SP	SCREW 11/64-40 L=8				2.00
31	40009001	PLATE SPRING				1.00
32	40009003	SET NUT				1.00
33	B1156781000	RUBBER BUSHING				2.00
34	BP800000000	VINYL TUBE, WHITE D=8				0.10
35	CQ303000000	OIL WICK				0.10
36	40009360	OIL PUMP BASE				1.00
37	SS4110815SP	SCREW 11/64-40 L=8				1.00
38	B3570771000	FILTER				1.00
39	B3546771000	OIL FELT				1.00
40	40009375	SPRING				1.00
41	40009366	FILTER SCREEN				1.00
42	40009379	BUSHING HOLDER				1.00
43	SS7090910SP	SCREW 9/64-40 L= 8.5				1.00
44	NS6090310SP	NUT 9/64-40				1.00
45	NS6150310SP	NUT 15/64-28				8.00
46	40008994	DRIVING PIN BASE	ACCESSORY PARTS			1.00
47	B11517810A0A	MACHINE BASE ASM.				1.00

48	B11517810AAA	MACHINE BASE ASM.	FOR URBAN WHITE			1.00
49	B1151781000A	MACHINE BASE		*		1.00
50	B115178100A	HEAD BASE	FOR URBAN WHITE	*		1.00
51	40008996	GUIDE PIN		*		2.00
52	40009035	RUBBER CUSHION		*		4.00
53	SS7111120SP	SCREW 11/64-40 L=10.5		*		4.00
54	B1122761000	HINGE HOLDER		*		2.00
55	26109207	HINGE HOLDER	FOR URBAN WHITE	*		2.00
56	B1120761000	PIN		*		2.00
57	SM6062002TP	SCREW M6 L=20		*		4.00
58	WP0621016SD	WASHER 6.2X13X1		*		4.00
59	SS6741010SP	SCREW 3/8-28 L=10		*		2.00
60	B8219125000	OIL DRAIN CAP GASKET		*		2.00
61	40009244	STARTING LEVER PRESSURE SPRING		*		1.00
62	SM9082003CP	SCREW M8 L=20		*		1.00
63	NS6150310SP	NUT 15/64-28		*		1.00
64	40009235	STOP SCREW ASM.		*		1.00
65	NM6080721SE	NUT M8		*		1.00
66	SS7151210SP	SCREW 15/64-28 L=12		*		1.00
67	40009231	STARTING LINK SHAFT		*		1.00
68	SS9150860SP	SCREW 15/64-28 L=8		*		1.00
69	SS8150710SP	SCREW 15/64-28 L=7		*		1.00
70	26107409	STARTING LINK		*		1.00
71	B2655781000	STARTING LEVER		*		1.00
72	RE0600000K0	E-RING 6	ACCESSORY PARTS			1.00
73	B71607810A0	SHIFTER DRIVING PIN	ACCESSORY PARTS			1.00
74	SS7112420SP	SCREW 11/64-40 L=24	ACCESSORY PARTS			3.00
75	B1133761000	MACHINE BASE FELT PAD				4.00
76	B1153771000	MACHINE BASE SCREW STUD				4.00
77	WP0612056SD	WASHER 6.1X18.5X2				4.00
78	B8213012000	BED HINGE CONNECTION				2.00
79	BP300000000	VINYL PIPE				0.13
80	BP500000000	VINYL PIPE				0.05
81	BP800000000	VINYL TUBE, WHITE D=8				0.10
82	BP400000000	VINYL TUBE, WHITE D=4				0.03

# SPEED TRANSMITTER COMPONENTS

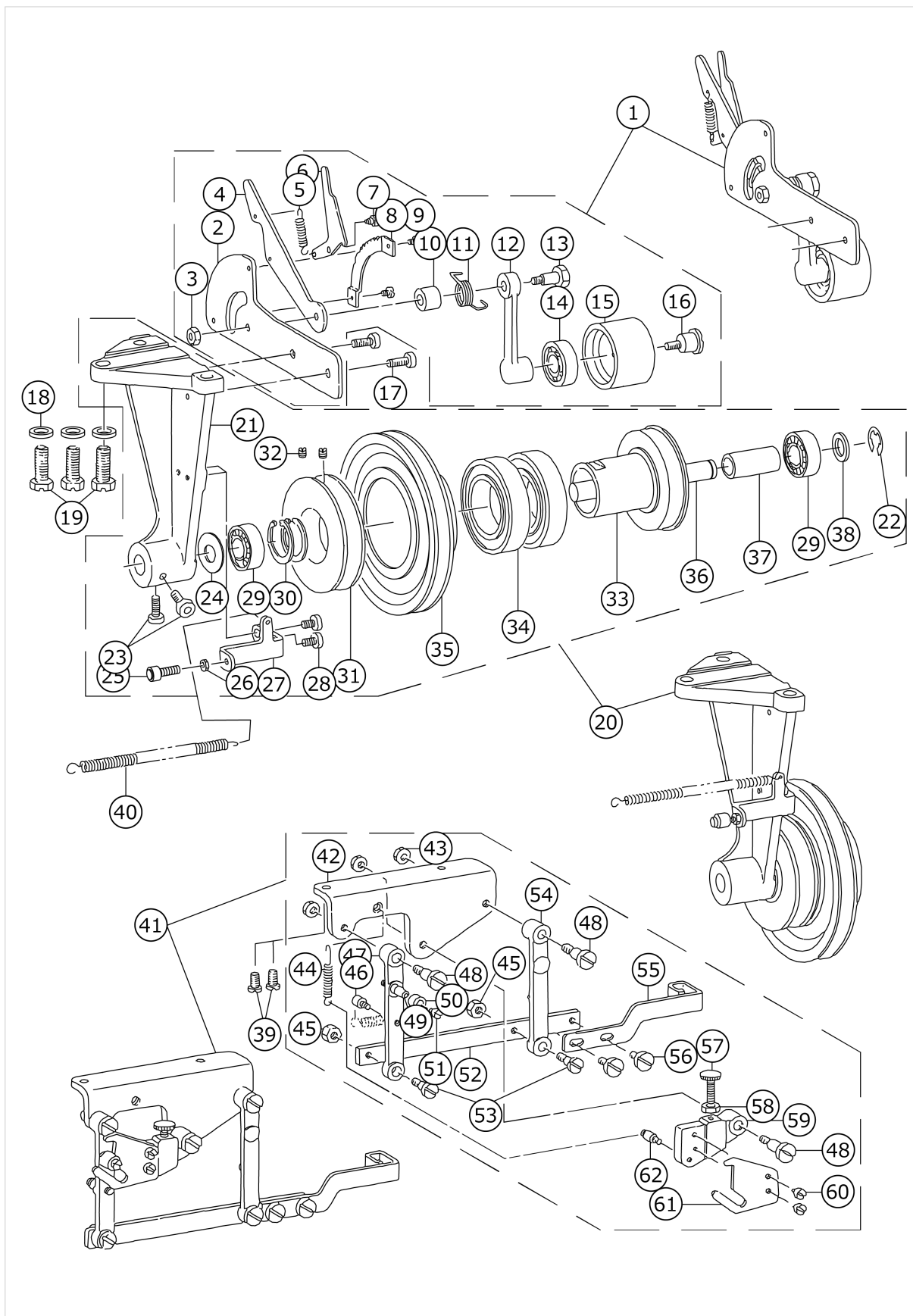



No.	品番	品名	備考	子部品	消耗品	個数
1	B71807810A0	TENSION PULLEY ASM.				1.00
2	40009388	TENSION PULLEY BRACKET		*		1.00
3	NS6150430SP	NUT 15/64-28		*		1.00
4	40009392	TENSION LEVER		*		1.00
5	B4419372000	NIPPER BAR ACTUATING LEVER SPRING		*		1.00
6	40009393	FIXING PAWL		*		1.00
7	SD0450211SP	HINGE SCREW D= 4.50 H= 2.1		*		1.00
8	B7186781000	RATCHET		*		1.00
9	SS7110710SP	SCREW 11/64-40 L=7		*		2.00
10	40009395	LEVER COLLAR		*		1.00
11	40009391	TENSION SPRING		*		1.00
12	40009390	TENSION PULLEY LINK		*		1.00
13	SD0902501SP	HINGE SCREW D=9 H=25		*		1.00
14	SB115000200	BEARING		*		1.00
15	40009389	TENSION PULLEY		*		1.00
16	SD1501101SP	HINGE SCREW D=14.5 H=11		*		1.00
17	SM6061202TP	SCREW M6 L=12				2.00
18	WP0651056SH	WASHER 6.5X11X1	ACCESSORY PARTS			3.00
19	SS9152130CP	SCREW 15/64-28 L=20.5	ACCESSORY PARTS			3.00
20	B71517810A0B	SPEED TRANSMITTER ASM.				1.00
21	B7151781000A	SPEED TRANSMITTER BRACKET		*		1.00
22	RE1200000K0	E-RING 12		*		1.00
23	SM6061202TP	SCREW M6 L=12		*		2.00
24	B122177100A	HIGH SPEED WASHER FOR BEARING		*		1.00
25	40009235	STOP SCREW ASM.		*		1.00
26	NS6150310SP	NUT 15/64-28		*		1.00
27	B7158781000	SHIFTER STOPPER BRACKET		*		1.00
28	SM6061202TP	SCREW M6 L=12		*		2.00
29	SB115000200	BEARING		*		2.00
30	RC3500002KP	RETAINING RING 35		*		2.00
31	B7155781000	ACCELERATING PULLEY		*		1.00
32	SS8150710SP	SCREW 15/64-28 L=7		*		2.00
33	B7154781000	HIGH-SPEED PULLEY		*		1.00
34	SB145000400	BEARING		*		2.00
35	B7156781000A	LOW-SPEED PULLEY		*		1.00
36	B7152781000A	SPEED TRANSMITTER SHAFT		*		1.00
37	B7153781000	SLEEVE		*		1.00
38	WP1502500SC	WASHER 15X24X2.5		*		1.00
39	SS7151210SP	SCREW 15/64-28 L=12	ACCESSORY PARTS			2.00
40	B7159781000	SHIFTER TENSION SPRING	ACCESSORY PARTS			1.00
41	26101253	SHIFTER BASE ASM.				1.00
42	26101204	SHIFTER BASE		*		1.00
43	NS6150310SP	NUT 15/64-28		*		3.00
44	26102004	SHIFTER CAM SPRING		*		1.00
45	NS6160520SP	NUT 1/4-24		*		2.00
46	26102202	SHIFTER TENSION SPRING		*		1.00

47	26101402	SHIFTER DRIVING ARM		*		1.00
48	26102509	SHIFTER DRIVING ARM SCREW		*		3.00
49	26102103	SHIFTER CAM ROLLER STUD		*		1.00
50	26102301	SHIFTER CAM ROLLER		*		1.00
51	SS6080610TP	SCREW 1/8-44 L=6		*		1.00
52	26101600	SHIFTER INSTALLING PLATE		*		1.00
53	SD0790802SP	HINGE SCREW D= 7.94 H= 8.0		*		2.00
54	26101501	SHIFTER HOLDING ARM		*		1.00
55	26101709	SPEED TRANSMITTER SHIFTER		*		1.00
56	SS7161040SP	SCREW 1/4-24 L= 9.5		*		2.00
57	26101303	SHIFTER PIN		*		1.00
58	NS6150430SP	NUT 15/64-28		*		1.00
59	26101808	SHIFTER CAM INSTALLING BASE		*		1.00
60	SS7110910SP	SCREW 11/64-40 L=8.5		*		2.00
61	26101907	SHIFTER CAM		*		1.00
62	26102400	SHIFTER CAM SUSPENSION		*		1.00

# MOTOR PULLEY COMPONENTS

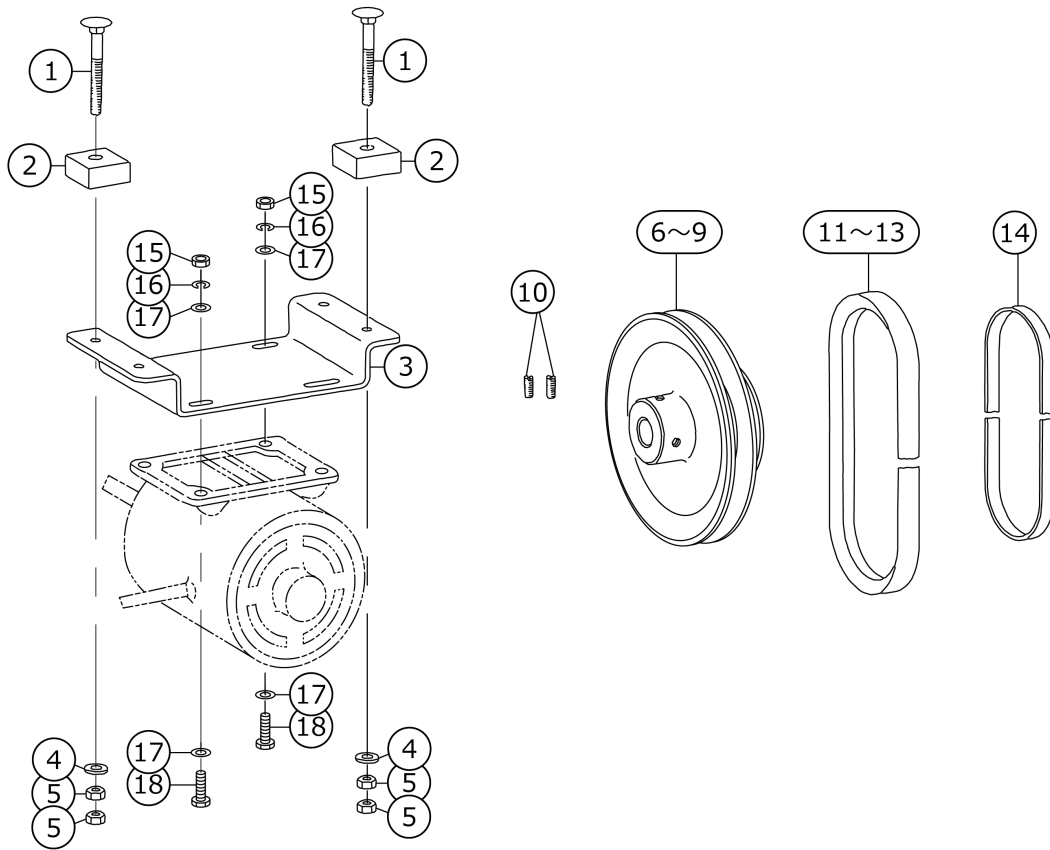

No.	品番	品名	備考	子部品	消耗品	個数
1	MTJMS000000	MOUNTING BOLT 5/16-18 L=70				4.00
2	B7109771000	SPACER				4.00
3	40009401	MOTOR BASE PLATE				1.00
4	WP0850002SC	WASHER 8.5X18X1.6				4.00
5	NS6200520SP	HEXAGONAL NUT 5/16-18				8.00
6	40009397	MOTOR PULLEY FOR 50HZ 3000SPM	SPECIAL ORDER PARTS			1.00
7	40009398	MOTOR PULLEY FOR 60HZ 3000SPM	SPECIAL ORDER PARTS			1.00
8	40009415	MOTOR PULLEY FOR 50HZ 3300SPM	SPECIAL ORDER PARTS			1.00
9	B7257781000A	MOTOR PULLEY FOR 60HZ 3300SPM	SPECIAL ORDER PARTS			1.00
10	SS8150710SP	SCREW 15/64-28 L=7				2.00
11	MTJVM004200	V-BELT 42INCH	SPECIAL ORDER PARTS			1.00
12	MTJVM004300	V-BELT 43INCH	SPECIAL ORDER PARTS			1.00
13	MTJVM004400	V-BELT 44INCH	SPECIAL ORDER PARTS			1.00
14	B7252781000	BELT				1.00
15	NM6060001SE	NUT M6X1 TYPE1				4.00
16	WS0621210KR	SPRING WASHER 6.2X11.4X1.2				4.00
17	WP0621016SD	WASHER 6.2X13X1				8.00
18	SM9062503SB	SCREW M6 L=25				4.00

# THREAD STAND COMPONENTS

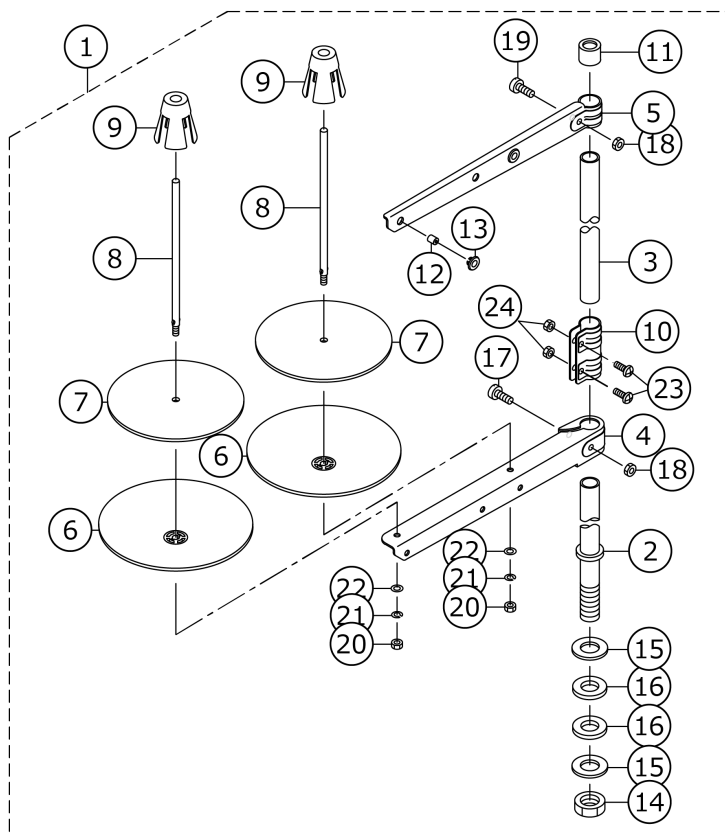

No.	品番	品名	備考	子部品	消耗品	個数
1	40096354	THREAD STAND ASM.				1.00
2	40085784	SPOOL REST ROD LOWER		*		1.00
3	40085785	SPOOL REST ROD UPPER		*		1.00
4	40085786	SPOOL REST ARM LOWER		*		1.00
5	40085787	SPOOL REST ARM UPPER		*		1.00
6	40085788	SPOOL REST		*		2.00
7	40085789	SPOOL REST CUSHION		*		2.00
8	40085790	SPOOL PIN		*		2.00
9	40085791	SPOOL RETAINER		*		2.00
10	40085792	SPOOL REST ROD JOINT		*		1.00
11	40085793	SPOOL REST ROD RUBBER CAP		*		1.00
12	40085794	THREAD GUIDE		*		2.00
13	40085795	THREAD GUIDE BUSHING		*		2.00
14	40096325	SPOOL REST ROD NUT		*		1.00
15	WP1612616SE	WASHER 16X30X2.6		*		2.00
16	40085796	SPOOL REST ROD RUBBER CUSHION		*		2.00
17	40096326	SPOOL REST ARM LOWER SCREW		*		1.00
18	NM6050001SE	NUT M5		*		2.00
19	40096327	SPOOL REST ARM UPPER SCREW		*		1.00
20	NM6050001SE	NUT M5		*		2.00
21	WS0510002KN	SPRING WASHER M5		*		2.00
22	WP0531001SC	WASHER M5		*		2.00
23	SM4051405SE	SCREW M5 L=14		*		2.00
24	NM6050001SE	NUT M5		*		2.00

# EXCLUSIVE PARTS FOR LBH-782, LBH-783, LBH-784

(1) LBH-782

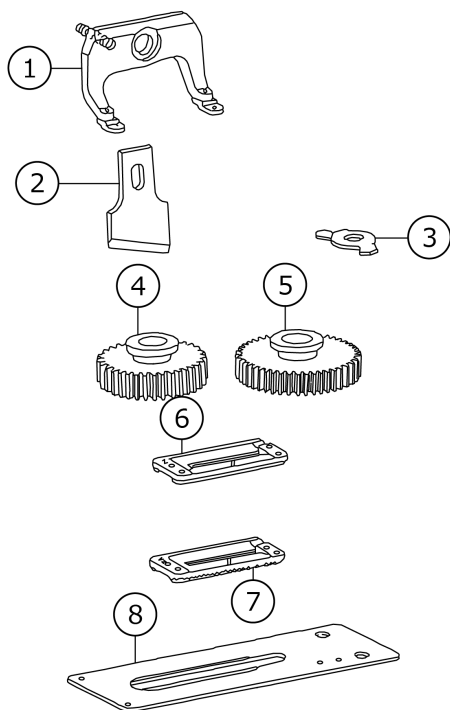

(2) LBH-783

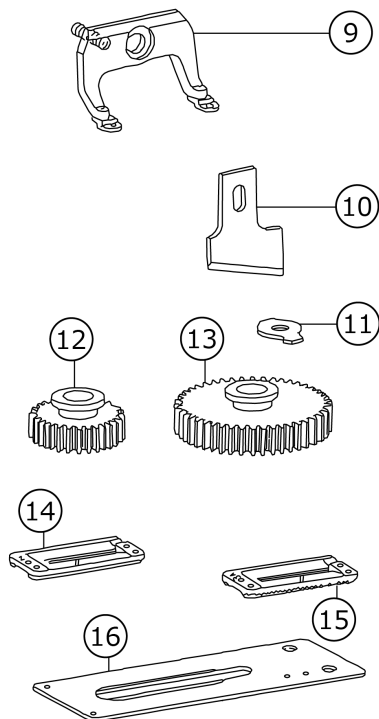

(3) LBH-784

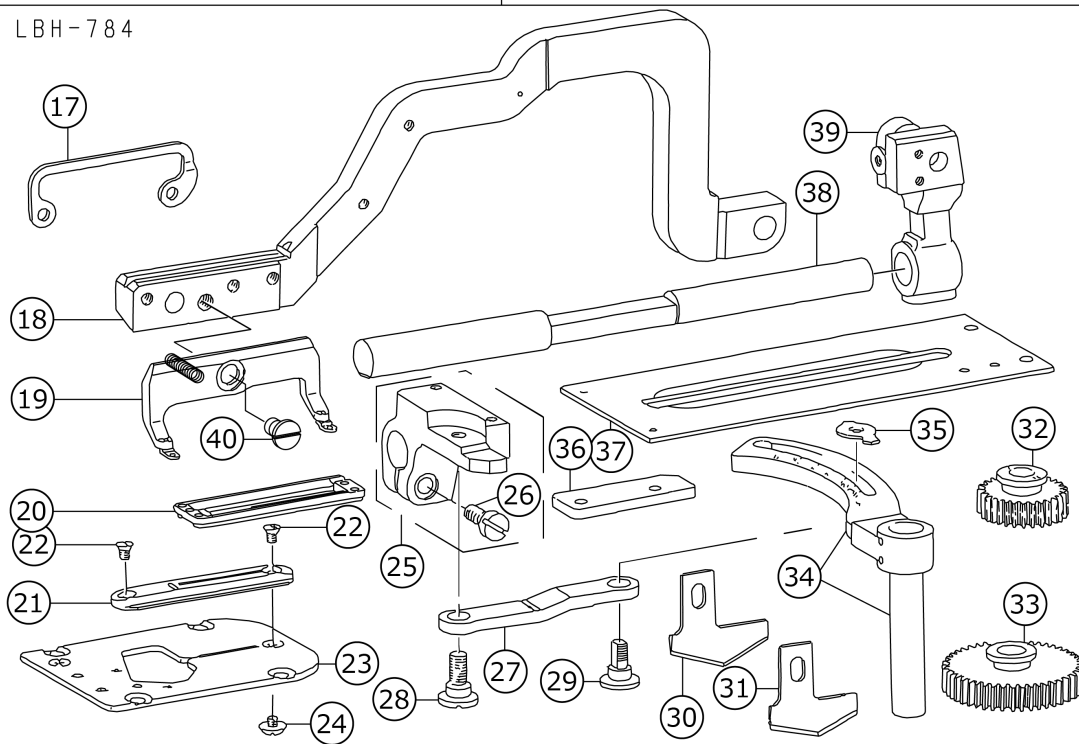

No.	品番	品名	備考	子部品	消耗品	個数
1	B15117720B0	WORK CLAMP CHECK HOLDER ASM.				1.00
2	B2702047Q00A	KNIFE 1				1.00
3	B1608772000	LENGTH REGULATING SHAFT GUIDE				1.00
4	B2930761000	SPUR GEAR (100)				1.00
5	B2931761000	SPUR GEAR (190)				1.00
6	B1552782000	WORK CLAMP CHECK, 2				1.00
7	B1508772A00	WORK CLAMP CHECK (2A)	SPECIAL ORDER PARTS FOR LIGHT WEIGHT KNIT MATERIALS.(PLEASE USE THE WORK CLAMP CHECK AND THE WORK CLAMP CARRIER TOGETHER AS A PAIR.)			1.00
8	B1613771A00A	WORK CLAMP CARRIER	SPECIAL ORDER PARTS FOR LIGHT WEIGHT KNIT MATERIALS.(PLEASE USE THE WORK CLAMP CHECK AND THE WORK CLAMP CARRIER TOGETHER AS A PAIR.)			1.00
9	B15117730B0	WORK CLAMP CHECK HOLDER ASM.				1.00
10	B2702047S00A	KNIFE 1-1/4				1.00
11	B1608761000	LENGTH REGULATING SHAFT GUIDE				1.00
12	B2948761000	SPUR GEAR (88)				1.00
13	B2949761000	SPUR GEAR (212)				1.00
14	B1552783000	WORK CLAMP CHECK, 3				1.00
15	B1508773A00	WORK CLAMP CHECK (3A)	SPECIAL ORDER PARTS FOR LIGHT WEIGHT KNIT MATERIALS.(PLEASE USE THE WORK CLAMP CHECK AND THE WORK CLAMP CARRIER TOGETHER AS A PAIR.)			1.00
16	B1613771A00A	WORK CLAMP CARRIER	SPECIAL ORDER PARTS FOR LIGHT WEIGHT KNIT MATERIALS.(PLEASE USE THE WORK CLAMP CHECK AND THE WORK CLAMP CARRIER TOGETHER AS A PAIR.)			1.00



17	B1513774000	WORK CLAMP BRACKET				1.00
18	B1551784000A	WORK CLAMP ARM (4)				1.00
19	B15117740A0	WORK CLAMP CHECK HOLDER ASM.				1.00
20	B1552784000	WORK CLAMP CHECK				1.00
21	B2402774000	THROAT PLATE				1.00
22	SS2090530SP	SCREW 9/64-40 L= 4.8				2.00
23	B24017740A0	THROAT PLATE BASE ASM.				1.00
24	SS5090320SP	SCREW 9/64-40 L= 3.2				1.00
25	B16117740A0	WORK CLAMP ARM BRACKET ASM.				1.00
26	SS6151440SP	SCREW 15/64-28 L=14		*		1.00
27	B1606774000	WORK CLAMP CARRIER PITMAN				1.00
28	SD0870401SP	HINGE SCREW D= 8.73 H= 4				1.00
29	B1605774000	FEED ADJUSTING SHAFT				1.00
30	B274577400BA	KNIFE 1-1/2				1.00
31	B274577400AA	KNIFE 1-3/8				1.00
32	B2944761000	SPUR GEAR (74)				1.00
33	B2945761000	SPUR GEAR 252				1.00
34	B16037740A0	LENGTH REGULATING ARM ASM.				1.00
35	B1608774000	LENGTH REGULATING SHAFT GUIDE				1.00
36	B1612774000	WORK CLAMP ARM BRACKET GUIDE				1.00
37	40009447	WORK CLAMP CARRIER(4)				1.00
38	B1609774000	WORK CLAMP ARM SLIDE ROD				1.00
39	B1516774000	WORK CLAMP ARM BEARING BRACKET				1.00
40	SD0790203SP	HINGE SCREW D=7.94 H=2				1.00

# SPECIAL ORDER PARTS

(1) TAPE REEL COMPONENTS  
テープ装置関係

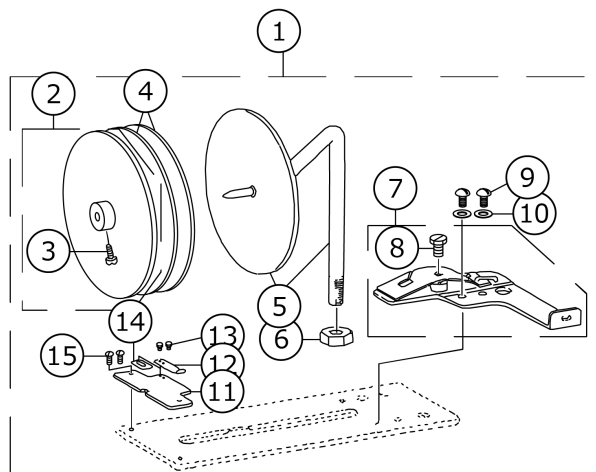

(2) BUTTON-HOLING MEASURING GAUGES  
ボタン穴間隔ゲージ

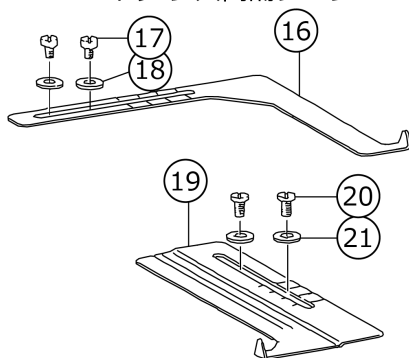

(3) KNIFE FOR SPECIAL  
特別用メス

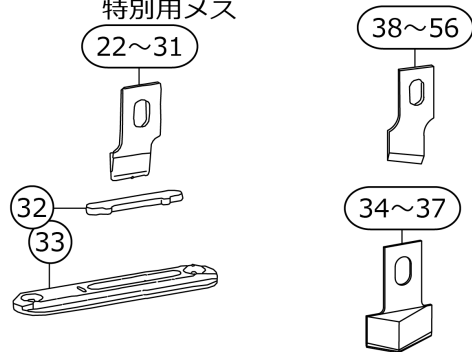

(4) HOOK OIL SHIELD COMPONENTS  
釜カバー関係

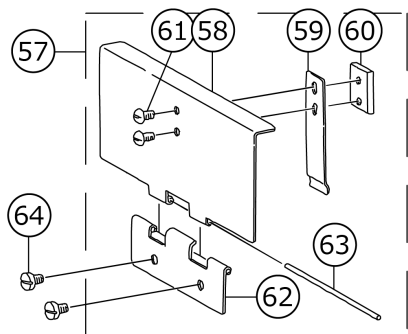

(5) COVER COMPONENTS  
カバー関係

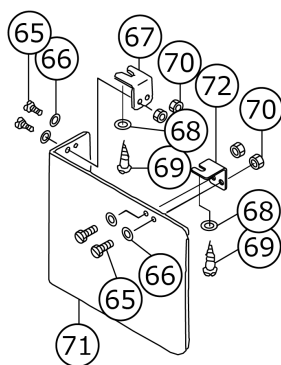

No.	品番	品名	備考	子部品	消耗品	個数
1	B92017610A0	REINFORCING TAPE ATTACHMENT ASM.				1.00
2	B92040470A0	TAPE ATTACHMENT SUPPORT PLATE ASM.		*		1.00
3	SS4090810SP	SCREW 9/64-40 L=8		*		1.00
4	B9205047000	ADJUSTING FELT		*		2.00
5	B92017610B0	REINFORCING TAPE ATTACHMENT ASM.		*		1.00
6	NS6700540SP	NUT 5/16-24		*		1.00
7	B92027610A0	TAPE GUIDE PLATE ASM.		*		1.00
8	SS5110740TP	SCREW 11/64-40 L= 6.5		*		1.00
9	SS7090510SP	SCREW 9/64-40 L= 4.6		*		2.00
10	WP0450000SD	WASHER 4.5X8X0.5		*		2.00
11	B9206761000	TAPE RETAINER		*		1.00
12	B9207761000	TAPE RETAINER SPRING		*		1.00
13	SS6060210SP	SCREW 3/32-56 L= 1.9		*		2.00
14	B9205761000	SPACER FOR TAPE RETAINER		*		1.00
15	SS5060410SP	SCREW 3/32-56 L=3.5		*		2.00
16	B9402771000	MEASURING GAUGE, CROSSWISE				1.00
17	SS6110610TP	SCREW 11/64-40 L=6				2.00
18	WP0501016SD	WASHER 5X10.5X1				2.00
19	B9401761000	DISTANCE MEASURING GAUGE				1.00
20	SS7110840SP	SCREW 11/64-40 L=7.8				2.00
21	WP0501016SD	WASHER 5X10.5X1				2.00
22	B2745771F00	KNIFE 1/4(FLUOROCARBON)	FOR FLUOROCARBON			1.00
23	B2745771K00	KNIFE 3/8(FLUOROCARBON)	FOR FLUOROCARBON			1.00
24	B2745771L00	KNIFE 1/2	FOR FLUOROCARBON			1.00
25	B2745771M00	KNIFE 5/8	FOR FLUOROCARBON			1.00
26	B2745771N00	KNIFE 3/4	FOR FLUOROCARBON			1.00
27	B2745771P00	KNIFE 7/8(FLUOROCARBON)	FOR FLUOROCARBON			1.00
28	B2745771Q00	KNIFE 1	FOR FLUOROCARBON			1.00
29	B2745771R00	KNIFE 1-1/8(FLUOROCARBON)	FOR FLUOROCARBON			1.00
30	B2745771S00	KNIFE 1-1/4	FOR FLUOROCARBON			1.00
31	B2745771H00	KNIFE 9/16 (FLUOROCARBON)	FOR FLUOROCARBON			1.00
32	B2746771000	KNIFE GUARD				1.00
33	B240277100B	THROAT PLATE (FLUOROCARBON)				1.00
34	B2745771P0B	KNIFE 7/8	FOR HEAVY WEIG HT MATERIALS			1.00
35	B2745771Q0B	KNIFE 1	FOR HEAVY WEIG HT MATERIALS			1.00
36	B2745771R0B	KNIFE 1-1/8	FOR HEAVY WEIG HT MATERIALS			1.00
37	B2745771S0B	KNIFE 1-1/4	FOR HEAVY WEIG HT MATERIALS			1.00

38	B2702047F00	KNIFE 1/4				1.00
39	B2702047K00A	KNIFE 3/8				1.00
40	B2702047I00	KNIFE (7/16)				2.00
41	B2702047L0A	KNIFE (1/2)				1.00
42	B2702047L00A	KNIFE 1/2				1.00
43	B2702047V0B	KNIFE 14				1.00
44	B2702047V00	KNIFE 9/16				1.00
45	B2702047M0A	KNIFE (5/8)				1.00
46	B2702047M00A	KNIFE 5/8				1.00
47	B2702047A00	KNIFE 11/16				1.00
48	B2702047N0A	KNIFE 3/4				1.00
49	B2702047N00	KNIFE 3/4				1.00
50	B2702047C00	KNIFE 13/16				1.00
51	B2702047P00	KNIFE 7/8				1.00
52	B2702047Q00A	KNIFE 1				1.00
53	B2702047R00	KNIFE 1-1/8				1.00
54	B2702047S0A	KNIFE 1-1/4				1.00
55	B2702047S00A	KNIFE 1-1/4				1.00
56	B2702047U00	KNIFE (1-1/2)				1.00
57	B11577710A0	HOOK OIL SHIELD ASM.				1.00
58	B1157771000	HOOK OIL SHIELD		*		1.00
59	B1158771000	HOOK OIL SHIELD SPRING		*		1.00
60	B1159771000	SPRING SET PLATE		*		1.00
61	SS5090610SP	SCREW 9/64-40 L=6		*		2.00
62	B1161771000	HOOK OIL SHIELD HINGE		*		1.00
63	B1160771000	HINGE PIN		*		1.00
64	SS7110510SP	SCREW 11/64-40 L=5				2.00
65	SS7110710SP	SCREW 11/64-40 L=7				4.00
66	WP0480856SP	WASHER 4.8X8.4X0.8				4.00
67	B7272781000	COVER MOUNTING BRACKET B				1.00
68	WP0501016SC	WASHER 5X10.5X1				2.00
69	SK3452000SE	WOOD SCREW D=4.5 L=20				2.00
70	NS6110310SP	NUT 11/64-40				4.00
71	B7273781000	SPEED TRANSMITTER COVER				1.00
72	26236703	COVER MOUNTING BRACKET C				1.00

# EXCHANGING PARTS

(1) TABLE OF CHANGING GEARS 交換齒車一覽表

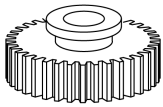
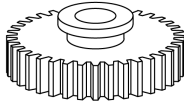
1. Small gear 小齒車				2. Large gear 大齒車			
							
Set 組	Stitch No. 針數	Part No. 品番		Stitch No. 針數	Part No. 品番		
		NO			NO		
A	54	1	B2936-761-000	345	16	B2937-761-000	
B	62	2	B2938-761-000	300	17	B2939-761-000	
C	66	3	B2940-761-000	285	18	B2941-761-000	
D	70	4	B2942-761-000	268	19	B2943-761-000	
E	74	5	B2944-761-000	252	20	B2945-761-000	
F	79	6	B2946-761-000	238	21	B2947-761-000	
G	83	7	B2928-761-000	225	22	B2929-761-000	
H	88	8	B2948-761-000	212	23	B2949-761-000	
I	93	9	B2950-761-000	200	24	B2951-761-000	
J	100	10	B2930-761-000	190	25	B2931-761-000	
K	105	11	B2952-761-000	180	26	B2953-761-000	
L	110	12	B2932-761-000	170	27	B2933-761-000	
M	115	13	B2954-761-000	160	28	B2955-761-000	
N	123	14	B2934-761-000	152	29	B2935-761-000	
O	130	15	B2956-761-000	145	30	B2957-761-000	

(2) TABLE SHOWING PARTS USED IN CONNECTION WITH KNIVES 刀關連表

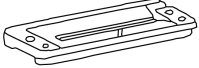
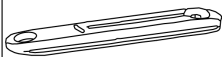
Knife メス			Work clamp check 押え			Throat plate 針板		
A			B			C		
								
Size (mm)	NO	Part No. 品番	NO	Part No. 品番	NO	Part No. 品番		
1/4" (6.35)	31	B2702-047-F00	42	B1552-781-000-A	46	B2402-771-000		
3/8" (9.53)	32	B2702-047-K00-A						
1/2" (12.7)	33	B2702-047-L00-A						
9/16" (14.29)	34	B2702-047-V00						
5/8" (15.88)	35	B2702-047-M00-A						
3/4" (19.05)	36	B2702-047-N00	43	B1552-782-000	47	B2402-774-000		
7/8" (22.23)	37	B2702-047-P00						
1" (25.4)	38	B2702-047-Q00-A	44	B1552-783-000	47	B2402-774-000		
1-1/4" (31.75)	39	B2702-047-S00-A						
1-3/8" (34.9)	40	B2745-774-00A-A	45	B1552-784-000	47	B2402-774-000		
1-1/2" (38.1)	41	B2745-774-00B-A						

Note (注記) Standard model machine is used as the standard for work clamp check and throat plate.  
押えと針板は標準機種を基準にしています。

No.	品番	品名	備考	子部品	消耗品	個数
1	B2936761000	SPUR GEAR (54)				1.00
2	B2938761000	SPUR GEAR (63)				1.00
3	B2940761000	SPUR GEAR (66)				1.00
4	B2942761000	SPUR GEAR (70)				1.00
5	B2944761000	SPUR GEAR (74)				1.00
6	B2946761000	SPUR GEAR (79)				1.00
7	B2928761000	SPUR GEAR (83)				1.00
8	B2948761000	SPUR GEAR (88)				1.00
9	B2950761000	SPUR GEAR (93)				1.00
10	B2930761000	SPUR GEAR (100)				1.00
11	B2952761000	SPUR GEAR (105)				1.00
12	B2932761000	SPUR GEAR (110)				1.00
13	B2954761000	SPUR GEAR (115)				1.00
14	B2934761000	SPUR GEAR (123)				1.00
15	B2956761000	SPUR GEAR (130)				1.00
16	B2937761000	SPUR GEAR (345)				1.00
17	B2939761000	SPUR GEAR (300)				1.00
18	B2941761000	SPUR GEAR (285)				1.00
19	B2943761000	SPUR GEAR (268)				1.00
20	B2945761000	SPUR GEAR 252				1.00
21	B2947761000	SPUR GEAR (238)				1.00
22	B2929761000	SPUR GEAR (225)				1.00
23	B2951761000	SPUR GEAR (200)				1.00
24	B2931761000	SPUR GEAR (190)				1.00
25	B2953761000	SPUR GEAR (180)				1.00
26	B2953761000	SPUR GEAR (180)				1.00
27	B2933761000	SPUR GEAR (170)				1.00
28	B2955761000	SPUR GEAR (160)				1.00
29	B2935761000	SPUR GEAR (152)				1.00
30	B2957761000	SPUR GEAR (145)				1.00
31	B2702047F00	KNIFE 1/4				1.00
32	B2702047K00A	KNIFE 3/8				1.00
33	B2702047L00A	KNIFE 1/2				1.00
34	B2702047V00	KNIFE 9/16				1.00
35	B2702047M00A	KNIFE 5/8				1.00
36	B2702047N00	KNIFE 3/4				1.00
37	B2702047P00	KNIFE 7/8				1.00
38	B2702047Q00A	KNIFE 1				1.00
39	B2702047S00A	KNIFE 1 - 1/4				1.00
40	B274577400AA	KNIFE 1 - 3/8				1.00
41	B274577400BA	KNIFE 1 - 1/2				1.00
42	B1552781000A	WORK CLAMP CHECK				1.00
43	B1552782000	WORK CLAMP CHECK, 2				1.00
44	B1552783000	WORK CLAMP CHECK, 3				1.00
45	B1552784000	WORK CLAMP CHECK				1.00
46	B2402771000	NEEDLE PLATE				1.00
47	B2402774000	THROAT PLATE				1.00

# EXCLUSIVE PARTS FOR LBH-781-K

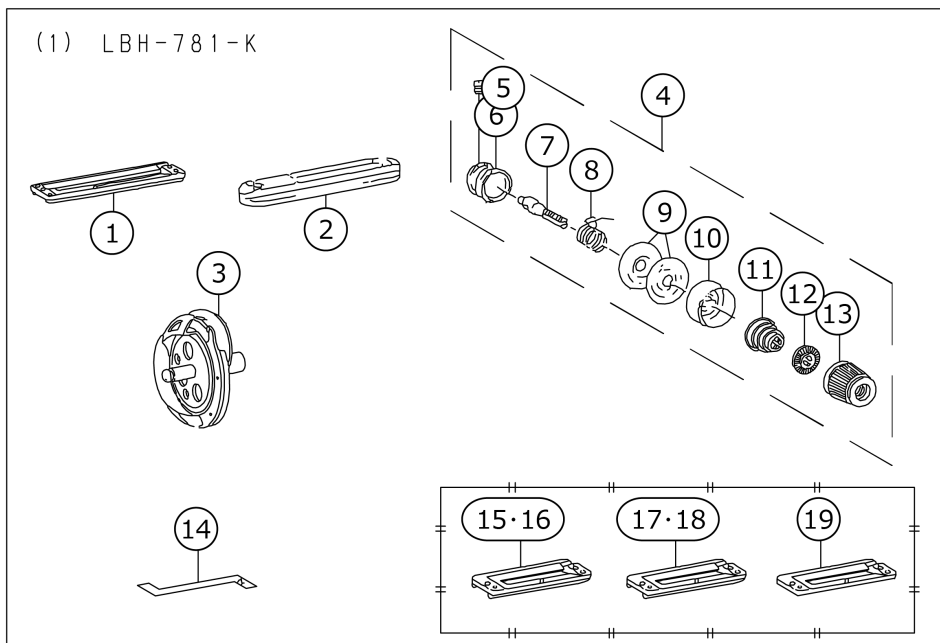

No.	品番	品名	備考	子部品	消耗品	個数
1	D1508771K00A	LATCH WORK CLAMP CHECK				1.00
2	D2402772K00	NEEDLE PLATE 2K				1.00
3	B18087610AB	HOOK ASM.				1.00
4	D3110772TA0	THREAD TENSION NO.3 ASM. K				1.00
5	SS8090670SP	SCREW 9/64-40 L= 5.5		*		1.00
6	B3110771000	TENSION POST SOCKET		*		1.00
7	B3111761000	TENSION POST NO.3		*		1.00
8	B3112761000	THREAD TAKE-UP SPRING		*		1.00
9	B3126012000	THREAD TENSION DISK		*		2.00
10	B3107804000	THREAD TENSION DISK PRESSER		*		1.00
11	B3129012A00	TENSION SPRING		*		1.00
12	B3120125000	ROTATING STOPPER		*		1.00
13	B3119771000	THREAD TENSION NUT		*		1.00
14	D9101771K00	HOOK TIMING GAUGE (K)				1.00
15	D1508771K0B	WORK CLAMP CHECK 5/8	SPECIAL ORDER PARTS FOR FLAT			1.00
16	D1508771K0C	WORK CLAMP CHECK 1/2	SPECIAL ORDER PARTS FOR FLAT			1.00
17	D1508771K0E	WORK CLAMP CHECK 5/8	SPECIAL ORDER PARTS FOR UNEV EN THICKNESS			1.00
18	D1508771K0F	WORK CLAMP CHECK 1/2	SPECIAL ORDER PARTS FOR UNEV EN THICKNESS			1.00
19	D1508771K0H	WORK CLAMP CHECK	SPECIAL ORDER PARTS FOR FRON T			1.00



# EXCLUSIVE PARTS FOR LBH-782-K, LBH-783-K

(1) LBH-782-K

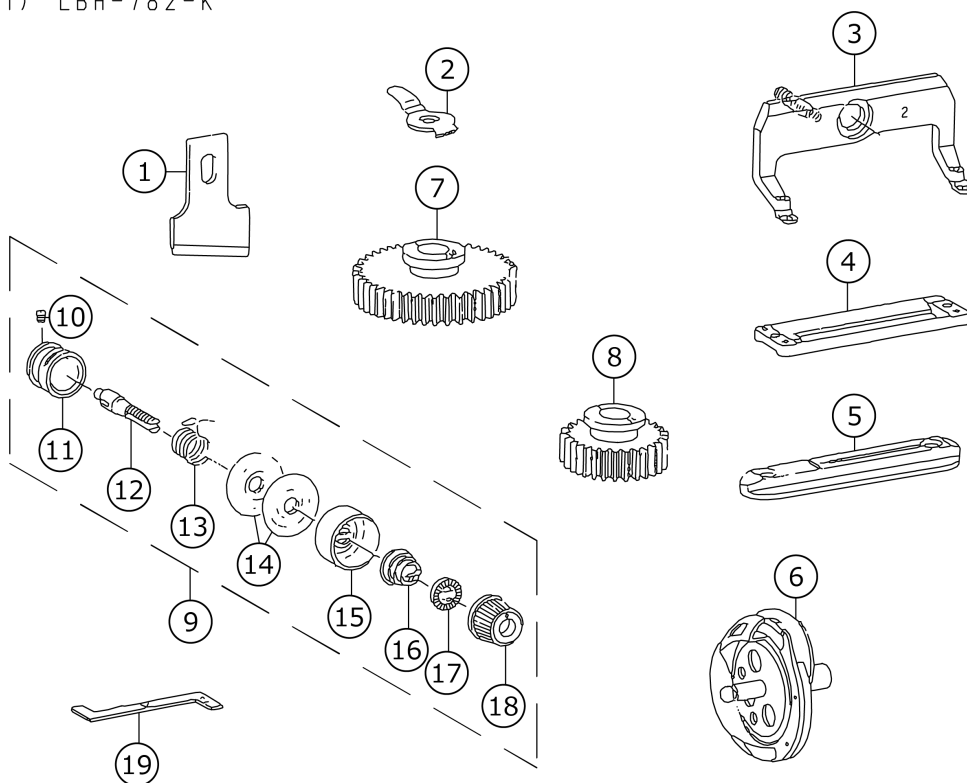

(2) LBH-783-K

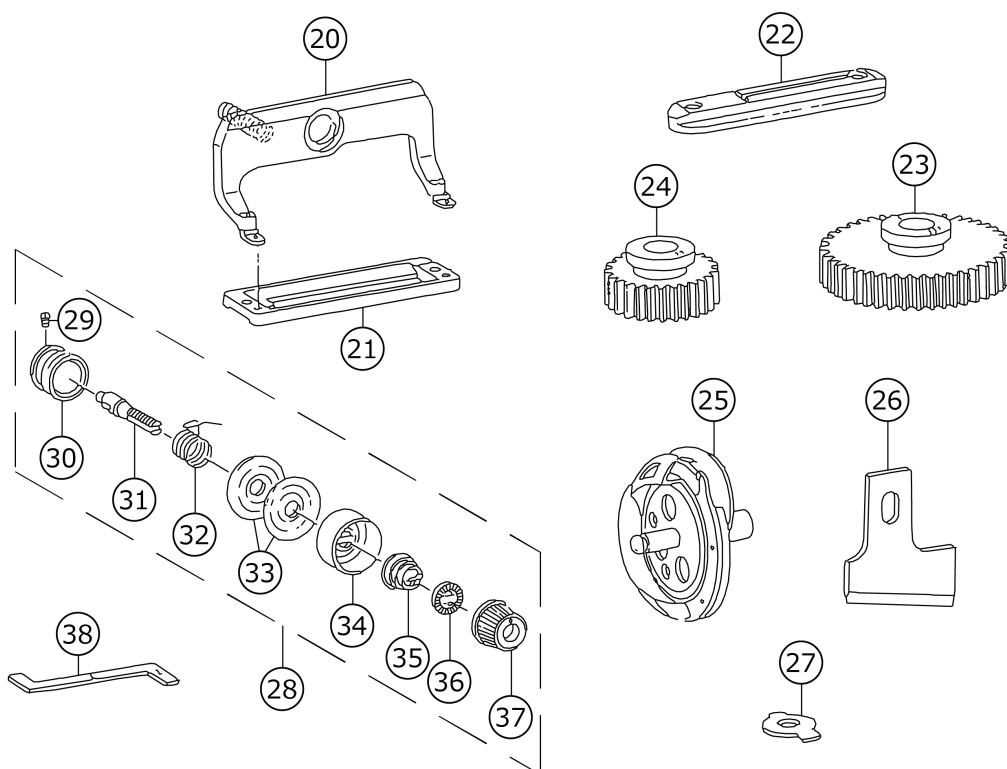

No.	品番	品名	備考	子部品	消耗品	個数
1	B2702047Q00A	KNIFE 1				1.00
2	B1608772000	LENGTH REGULATING SHAFT GUIDE				1.00
3	B15117720B0	WORK CLAMP CHECK HOLDER ASM.				1.00
4	D1508772K00	WORK CLAMP CHECK (2K)				1.00
5	D2402772K00	NEEDLE PLATE 2K				1.00
6	B18087610AB	HOOK ASM.				1.00
7	B2931761000	SPUR GEAR (190)				1.00
8	B2930761000	SPUR GEAR (100)				1.00
9	D3110772TA0	THREAD TENSION NO.3 ASM. K				1.00
10	SS8090670SP	SCREW 9/64-40 L= 5.5		*		1.00
11	B3110771000	TENSION POST SOCKET		*		1.00
12	B3111761000	TENSION POST NO.3		*		1.00
13	B3112761000	THREAD TAKE-UP SPRING		*		1.00
14	B3126012000	THREAD TENSION DISK		*		2.00
15	B3107804000	THREAD TENSION DISK PRESSER		*		1.00
16	B3129012A00	TENSION SPRING		*		1.00
17	B3120125000	ROTATING STOPPER		*		1.00
18	B3119771000	THREAD TENSION NUT		*		1.00
19	D9101771K00	HOOK TIMING GAUGE (K)				1.00
20	B15117730B0	WORK CLAMP CHECK HOLDER ASM.				1.00
21	D1508773K00	WORK CLAMP CHECK (3K)				1.00
22	D2402772K00	NEEDLE PLATE 2K				1.00
23	B2949761000	SPUR GEAR (212)				1.00
24	B2948761000	SPUR GEAR (88)				1.00
25	B18087610AB	HOOK ASM.				1.00
26	B2702047S00A	KNIFE 1 - 1/4				1.00
27	B1608762000	LENGTH REGULATING SHAFT GUIDE				1.00
28	D3110772TA0	THREAD TENSION NO.3 ASM. K				1.00
29	SS8090670SP	SCREW 9/64-40 L= 5.5		*		1.00
30	B3110771000	TENSION POST SOCKET		*		1.00
31	B3111761000	TENSION POST NO.3		*		1.00
32	B3112761000	THREAD TAKE-UP SPRING		*		1.00
33	B3126012000	THREAD TENSION DISK		*		1.00
34	B3107804000	THREAD TENSION DISK PRESSER		*		1.00
35	B3129012A00	TENSION SPRING		*		1.00
36	B3120125000	ROTATING STOPPER		*		1.00
37	B3119771000	THREAD TENSION NUT		*		1.00
38	D9101771K00	HOOK TIMING GAUGE (K)				1.00

# EXCLUSIVE PARTS FOR LBH-784-K

(1) LBH-784-K

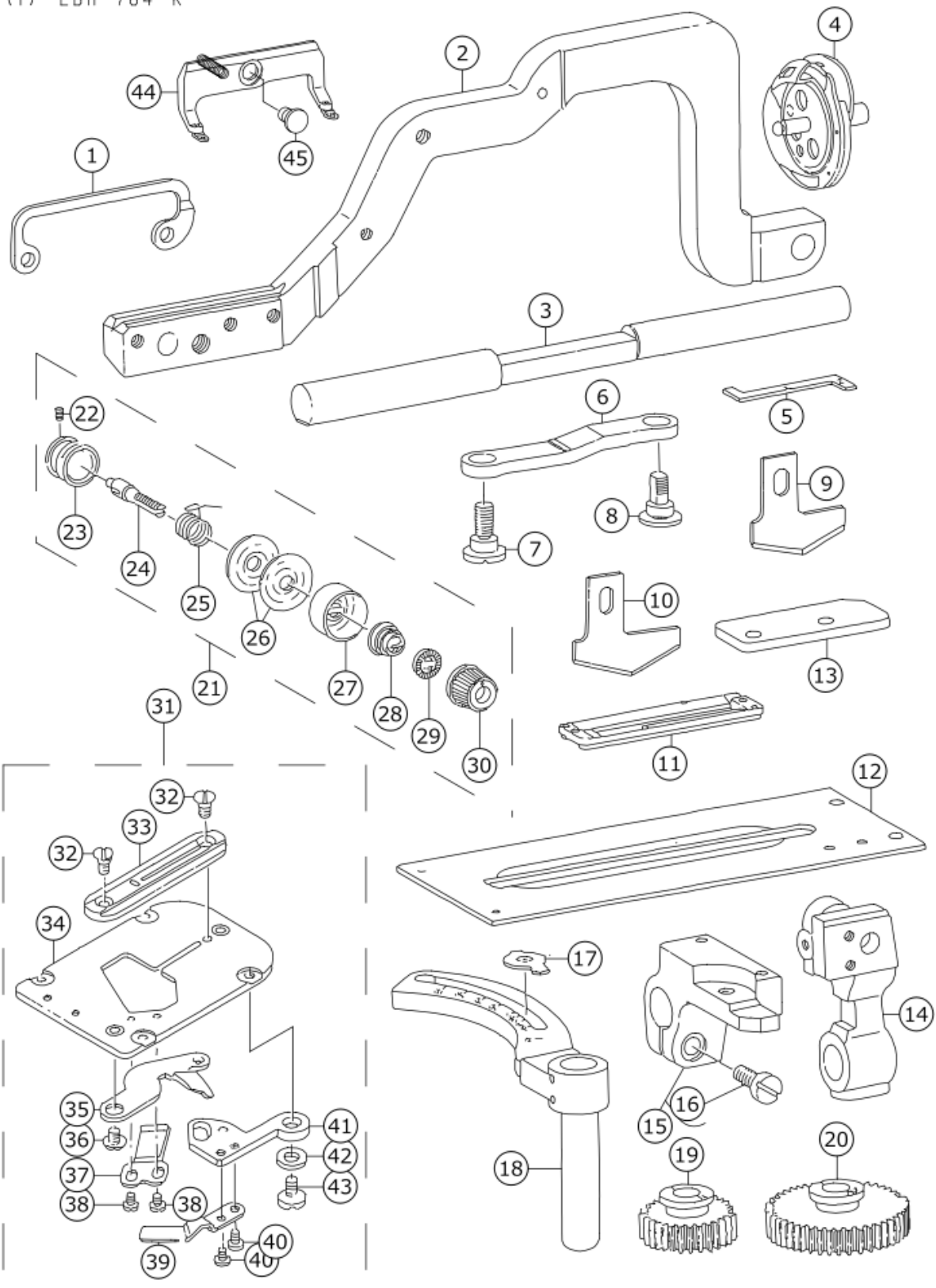

No.	品番	品名	備考	子部品	消耗品	個数
1	B1513774000	WORK CLAMP BRACKET				1.00
2	B1551784000A	WORK CLAMP ARM (4)				1.00
3	B1609774000	WORK CLAMP ARM SLIDE ROD				1.00
4	B18087610AB	HOOK ASM.				1.00
5	D9101771K00	HOOK TIMING GAUGE (K)				1.00
6	B1606774000	WORK CLAMP CARRIER PITMAN				1.00
7	SD0870401SP	HINGE SCREW D= 8.73 H= 4				1.00
8	B1605774000	FEED ADJUSTING SHAFT				1.00
9	B274577400BA	KNIFE 1-1/2				1.00
10	B274577400AA	KNIFE 1-3/8				1.00
11	D1508774K00	WORK CLAMP CHECK, K				1.00
12	40009447	WORK CLAMP CARRIER(4)				1.00
13	B1612774000	WORK CLAMP ARM BRACKET GUIDE				1.00
14	B1516774000	WORK CLAMP ARM BEARING BRACKET				1.00
15	B16117740A0	WORK CLAMP ARM BRACKET ASM.				1.00
16	SS6151440SP	SCREW 15/64-28 L=14		*		1.00
17	B1608774000	LENGTH REGULATING SHAFT GUIDE				1.00
18	B16037740A0	LENGTH REGULATING ARM ASM.				1.00
19	B2944761000	SPUR GEAR (74)				1.00
20	B2945761000	SPUR GEAR 252				1.00
21	D3110772TA0	THREAD TENSION NO.3 ASM. K				1.00
22	SS8090670SP	SCREW 9/64-40 L= 5.5		*		1.00
23	B3110771000	TENSION POST SOCKET		*		1.00
24	B3110761000	TENSION POST SOCKET		*		1.00
25	B3112761000	THREAD TAKE-UP SPRING		*		1.00
26	B3126012000	THREAD TENSION DISK		*		2.00
27	B3107804000	THREAD TENSION DISK PRESSER		*		1.00
28	B3129012A00	TENSION SPRING		*		1.00
29	B3120125000	ROTATING STOPPER		*		1.00
30	B3119771000	THREAD TENSION NUT		*		1.00
31	D2401774K00	NEEDLE PLATE ASM.				1.00
32	SS2090530SP	SCREW 9/64-40 L= 4.8		*		2.00
33	D2402774K00	NEEDLE PLATE 4K		*		1.00
34	B24017740A0	THROAT PLATE BASE ASM.		*		1.00
35	B24067710A0	BOBBIN THREAD TRIMMER BLADE ASM.		*		1.00
36	SS5090320SP	SCREW 9/64-40 L= 3.2		*		1.00
37	B2408771000A	COUNTER KNIFE		*		1.00
38	SS4080310SP	SCREW 1/8-44 L=3.4		*		2.00
39	B2405771000	BOBBIN THREAD PULLER		*		1.00
40	SS6090440SP	SCREW 9/64-40 L= 4.0		*		2.00
41	B2404771000	BOBBIN THREAD TRIMMER LEVER		*		1.00
42	WP0451016SP	WASHER 4.5X20X1		*		1.00
43	SS5090320SP	SCREW 9/64-40 L= 3.2		*		1.00
44	B15117740A0	WORK CLAMP CHECK HOLDER ASM.				1.00
45	SD0790203SP	HINGE SCREW D=7.94 H=2				1.00



# HOW TO MAKE USE OF THIS PARTS LIST

## 1.Explanation of codes

1)"\*"mark.....means this part is changed from the previous parts book.

As to the details of the change, refer to the "List for information of change".

2)"#01".....refer to "Note" explanation at bottom of page.

## 2.Codes on the "Qty" column

· Each numeral indicates the number of parts required.

· "0.1" and "2.5" indicate the length (in meters) of the respective parts.

3.Parentheses mean that the corresponding part is a subpart that constructs an assembly part.

4.Dotted lines on the Figures indicate assembly parts.

## 1 ."注記"欄の記号説明

1) "\*"印.....前回のパーツブックに比較して今回変更された部品を意味します。

変更内容は、"変更情報リスト"を参照してください。

2) "#01".....ページ下の"注記"の説明を参照してください。

2.数量欄の数字は、個数を表し、0.1、2.5等の数値は、長さ（単位メートル）を表します。

3.数量欄の（ ）は、組部品を構成している子部品であることを意味します。

4.イラストページの-----枠は、組構成であることを意味します。